

PERFORMANCE WITH **SAFETY**



**Switch-Disconnector-Fuse
Switch-Disconnector**



Contents

| | |
|--------------------------|----|
| Standards & Approvals | 1 |
| All about switches | 2 |
| FN Family | 6 |
| Product Features | 9 |
| Technical Specifications | 12 |
| Selection of Handle | 15 |
| Ordering Information | 16 |
| Spares and Accessories | 17 |
| HRC Fuses | 18 |
| Characteristic Curves | 26 |
| Overall Dimensions | 29 |

| | |
|-------------------------|----|
| CZ Switch Disconnectors | 48 |
| Product Range | 49 |
| Overall Dimensions | 55 |

Standards & Approvals



Switch-Disconnector-Fuse range comply with following standards

- › **IEC 60947-1, EN 60947-1, IS/IEC 60947-1**
Low-voltage switchgear and controlgear, Part 1: General Rules
- › **IEC 60947-3, EN 60947-3, IS/IEC 60947-3**
Low-voltage switchgear and controlgear, Part 3: Switches, disconnectors, switch-disconnectors and fuse combination units



- › **NABL**
NABL accreditation is a formal recognition of the technical competence of testing, calibration or medical laboratory for a specific task following ISO/IEC 17025:2005 Standard. Accredited laboratories have the responsibility of satisfying the criteria of laboratory accreditation at all times, which are verified during Surveillance and Reassessment visits by NABL. Further the accredited laboratories should prove their technical competence by satisfactory participation in recognized Proficiency Testing Programmes.

Lauritz Knudsen Electrical & Automation Testing Lab is NABL accredited subject to continued satisfactory compliance to above standard & additional requirements of NABL.

Switch-Disconnector-Fuse range is tested in Lauritz Knudsen Electrical & Automation NABL accredited Switchgear Testing Lab.



- › **CE Marking**
A CE marking is an European marking of conformity that indicates a product complies with the essential requirements of the applicable European laws or directives with respect to safety, health and environment and consumer protection. Generally, this conformity to the applicable directives is done through self-declaration and is required on products in the countries of the European Economic Area (EEA) to facilitate trade among the member countries. The manufacturer or their authorized representative established in the EEA is responsible for affixing the CE marking to their product. The CE marking provides a means for a manufacturer to demonstrate that a product complies with a common set of laws required by all countries in the EEA to allow free movement of trade within the EEA countries.

Lauritz Knudsen Electrical & Automation Switch-Disconnector range conform to the Low voltage directive 73/23/EEC as amended by directive 93/68/EEC, provided it is used in the application for which it is made and is installed and maintained in accordance with professional practices with relevant installation standards and operating instructions.











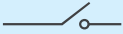
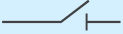
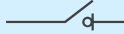

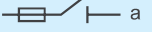
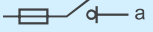
All about switches

Lauritz and Knudsen brings you a basket of switching solutions.

These switches guarantee performance in challenging environment coupled with unmatched reliability, these switching solutions are thriving in ruling in innumerable industrial and commercial installations. These switches are easy to install, use and inspect. All the switches also come with standard protective features such as terminal shrouds, phase barriers and high ground clearances.

Different Switch representations according to IEC 60947-3

Table 1 - Summary of equipment definitions

| Function | | |
|-----------------------------------------------------------------------------------------------------------------|-----------------------------------------------------------------------------------------------------------------------|--------------------------------------------------------------------------------------------------------------------------------|
| Making and breaking current | Isolating | Making, breaking and isolating |
| Switch  | Disconnecter  | Switch-Disconnecter  |
| Fuse combination units | | |
| Switch-fuse single break  | Disconnecter-fuse single break  | Switch-disconnector-fuse single break  |
| Switch-fuse double break  | Disconnecter-fuse double break  | Switch-disconnector-fuse double break  |
| Fuse-switch single break  | Fuse-disconnector single break  | Fuse-switch disconnecter single break  |
| Switch-fuse double break  | Disconnecter-fuse double break  | Switch-disconnector-fuse double break  |

A disconnecter is a mechanical device that fulfills the requirements specified for the isolation function in the open position, as specified in IEC 60947-1.

The purpose of an isolator is to cut off the supply from all or a discrete section of the installation by separating the installation or section from every source of electrical energy for safety reasons.

Load switches (or only “switches”) are mechanical switching devices capable of making, carrying and breaking currents

under normal circuit conditions which may include specified operating overload conditions and also carrying for a specified time currents under specified abnormal circuit conditions such as those of short-circuit.

Switch Disconnecter Fuses have combined properties of load switches and disconnectors in addition to the protection offered by fuses.

All about switches

Utilization Category of S-D-Fs & S-Ds

The Utilization Category of any equipment indicates the type of electrical load and duty cycle of the load; it is characterized by one or more of the following service conditions:

- › Rated operated current
- › Rated operated voltage
- › Power factor
- › Short circuit performance (making & breaking capacity)
- › Selection of equipment

| Product Standard | Utilization Category | Application |
|-------------------------------------------------|----------------------|--------------------------------------------------|
| SDFs, Changeovers, SDs IS/IEC 60947 (Part 3) | 20 | Connecting and disconnecting under no-load |
| | 21 | Switching of Resistive loads |
| | 22 | Switching of mixed resistive and inductive loads |
| | 23 | Switching of motor or highly inductive load |

Contains suffix: Category A (frequent) or Category B (infrequent) operation

Utilization Category is very important in defining

- › Electrical & Mechanical life of the equipment.
- › Making & Breaking Capacity of the equipment.

Operational Performance as per standard

| Ie, (A) | Category A | | | Category B | | |
|-----------|-------------|--------------|-------|-------------|--------------|-------|
| | w/o current | With current | Total | w/o current | With current | Total |
| 0-100 | 8500 | 1500 | 10000 | 1700 | 300 | 2000 |
| 100-315 | 7000 | 1000 | 8000 | 1400 | 200 | 1600 |
| 315-630 | 4000 | 1000 | 5000 | 800 | 200 | 1000 |
| Above 630 | 2500 | 500 | 3000 | 500 | 100 | 600 |

Category A demands for **5 times more** electrical and mechanical life as compared to B

| Utilization Category | Making Power Factor | Breaking Power Factor |
|----------------------|---------------------|-----------------------|
| AC-22 | 0.8 | 0.8 |
| AC-23 | 0.65 | 0.65 |

All about switches

Making & Breaking Capacity as per standard

| Utilization Category | Making Capacity | | Breaking Capacity | |
|----------------------|-----------------|-------|-------------------|-------|
| | I /Ie | Cos Ø | I /Ie | Cos Ø |
| AC-22 | 3 | 0.65 | 3 | 0.65 |
| AC-23 (0<Ie<100) | 10 | 0.45 | 8 | 0.45 |
| AC-23 (Ie>100) | 10 | 0.35 | 8 | 0.35 |

AC-23 is a far stringent test as current is 3.33 times as that in AC-22. Also, power factor in AC-23 is 0.45 (0.35 in higher ratings). Operating at stringent power factor in AC 23 implies that thermal performance of the switch would be superior in AC-22 installation.

Benefits of AC-23A Utilization Category

- › The electrical and mechanical life of type A switches is 5 times as that of type B switches
- › Testing for AC-23A ensures ruggedness
- › AC-23A switches run cooler at lighter loads
- › AC-23A switches work well in low power factor conditions

Utilization Category of FN Switches is AC-23A

Does Neutral Link need to be isolated? Lets find out...

Clause 8.2 of IEC 60079-14 (2007) requires the provision of suitable means of isolation, such as isolators, fuses, and links, for each circuit or group of circuits in hazardous areas to ensure safe maintenance work. In TN-S systems commonly used in hazardous area installations, the transformer star-point is usually connected to an earth rod or to the earth grid and a neutral connection is connected to the switchgear. This is also called a solidly earthed system. This is necessary to maintain a neutral potential as close to 'zero' as possible. This minimises the risk of electric shock and ensures that the upstream earth fault protection devices clear the fault current very quickly.

In hazardous areas, it is necessary that the neutral is completely isolated when maintenance work is required to be undertaken. If the neutral is not electrically separated and a fault occurs elsewhere in the same network then the neutral in the hazardous area could have its potential elevated sufficiently above zero to cause a spark or electric shock.

Neutral isolation is also necessary in applications that have both a mains supply source and a standby power supply source to prevent harm to maintenance personnel when only one

1. Ensure the switch is in OFF condition
2. Remove the link by unscrewing two screws
3. Store the neutral link carefully
4. Proceed for maintenance activity

source is feeding and the other is off. The neutral conductor is a current-carrying conductor and must be isolated from the grounding system within a facility to prevent danger from stray currents and electromagnetic fields. It is critical to keep power supply wires balanced to prevent overheating, fire, electrical shock, and premature breakdown of the electrical system.

To achieve neutral isolation, 4-pole or TPN circuit breakers / SDFs or 2-pole SDFs/circuit breakers are required for three-phase and single-phase systems, respectively.

Further when it comes to Switch Disconnecter Fuses, the TPN is the most widely used configuration. Here, it is important that the neutral is 'isolable' instead of a solid link. This ensures that neutral is always connected in the system when the feeder is operational and can be disconnected or isolated during maintenance activity by simply unscrewing the neutral link.

As seen from the below diagram, disconnecting the neutral link is an easy 4-step procedure to ensure safety!

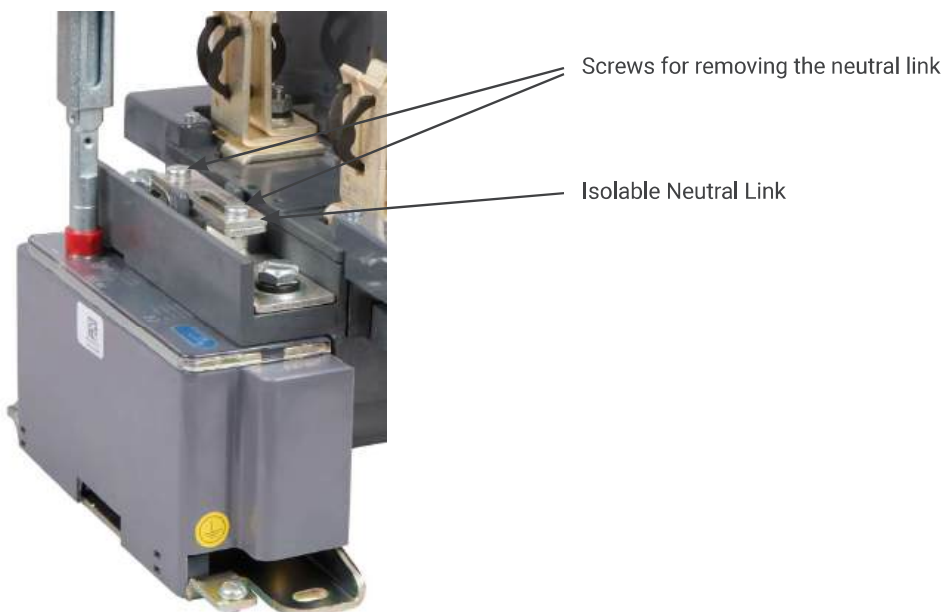

FN

FN offers you a unique series of Switch-Disconnecter-Fuse combining compactness with high performance & customer convenience.

Range covers ratings from 32A to 800A in 5 frame sizes catering to:

- › 2P applications
- › 3P applications
- › TPN applications
- › 4P/Switched Neutral applications
- › DC application
- › Higher voltage (690V AC) applications

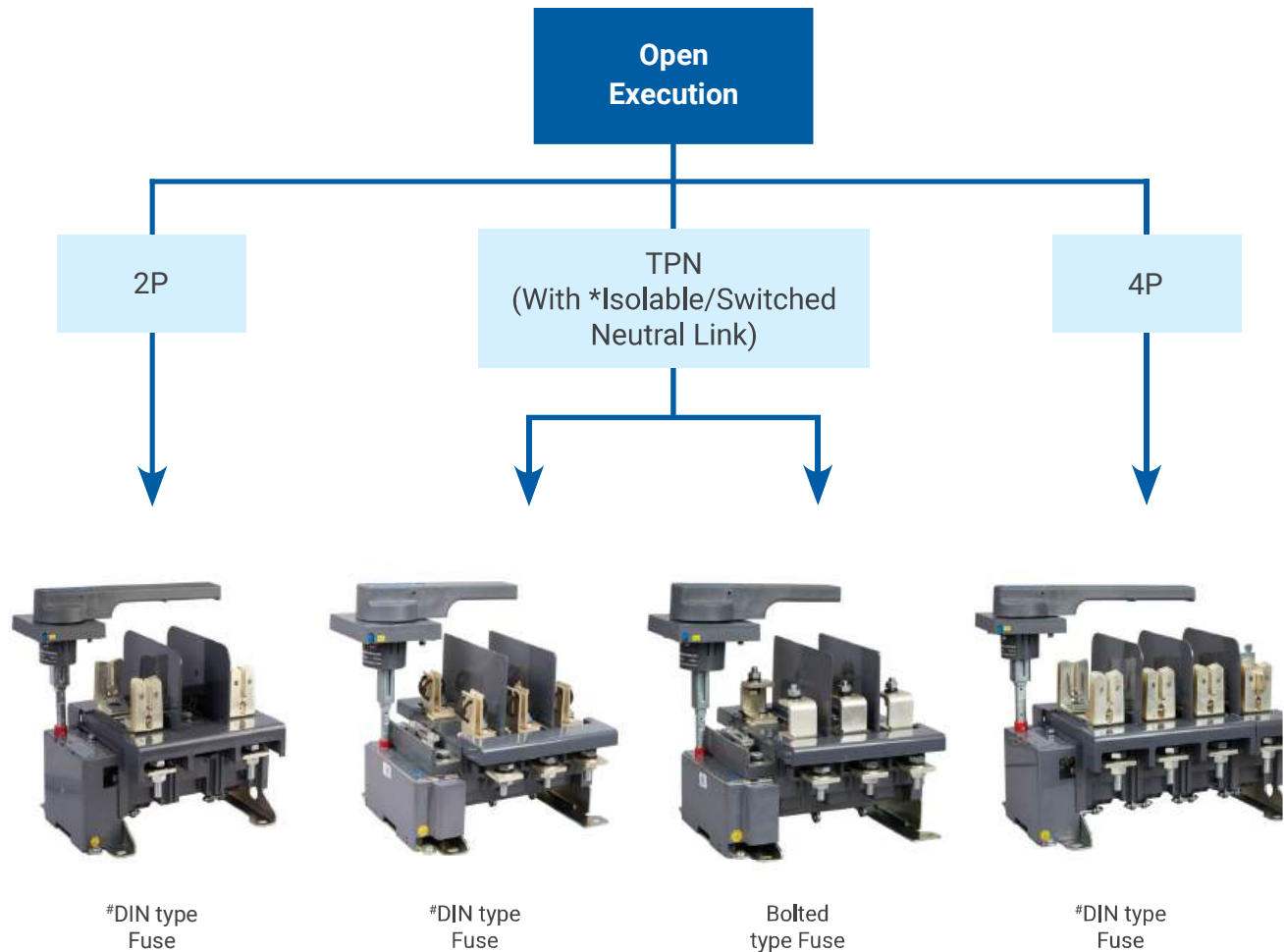

§415V, 32A to 800A

Frame 1: FN 32/63

Frame 2: FN 100/125/160

* Switched Neutral in case of FN 32/63

Upto 63A- Cylindrical fuses

§ 690V and DC ratings indicated in Technical Specifications

Family

Special version
for Harsh
Environment

FN S-D-F with corrosion protection have been designed for use in sulphur-rich environments.

TPN



Bolted
type Fuse

Spacious Sheet Steel
Enclosure version

SDF in spacious Sheet Steel Enclosure: Complete range of SDF is also available in attractive powder coated sheet steel enclosures.

FN 32 / 63 in sheet steel enclosure comes fitted with gland plate. Separate cable gland boxes are not required.

TPN



#DIN type
Fuse



Switch Disconnecter
Version is also
available (2P, TPN, 4P)

Frame 3: FN 200/250

Frame 4: FN 315/400

Frame 5: FN 630/800

FN S-D-F

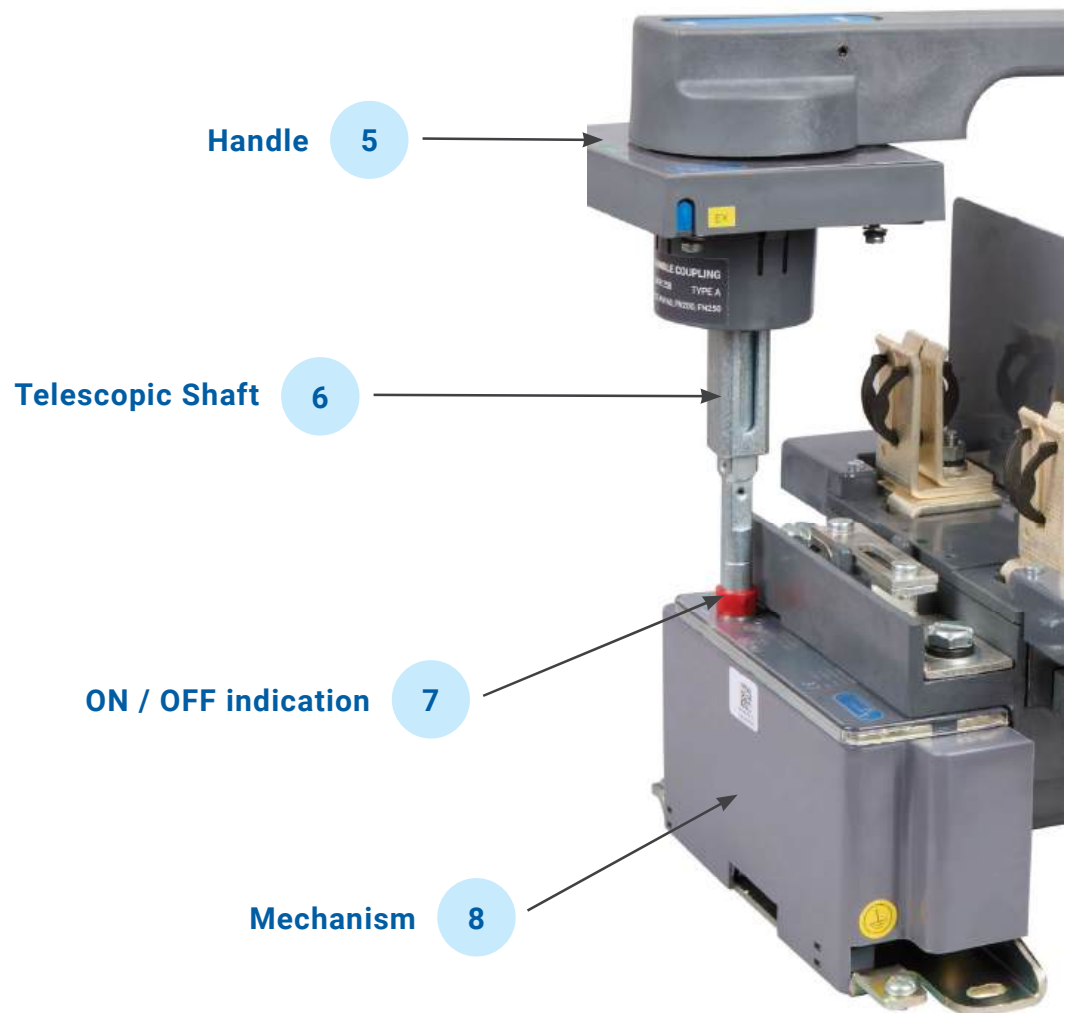

Safety

- › Terminal shrouds
- › Separate arcing / Current carrying zone
- › High clearance & creepages
- › Separate bridge for each pole
- › Fuse stationary during switching operations & isolated from both sides
- › Phase barriers
- › Maximum ground clearance



Superior and reliable technology

- › Electrodynamic compensation
- › Quad break contact system enhances electrical life
- › Full AC - 23 A rating for the complete range
- › Quick make / Quick break / Positive break

Product Features

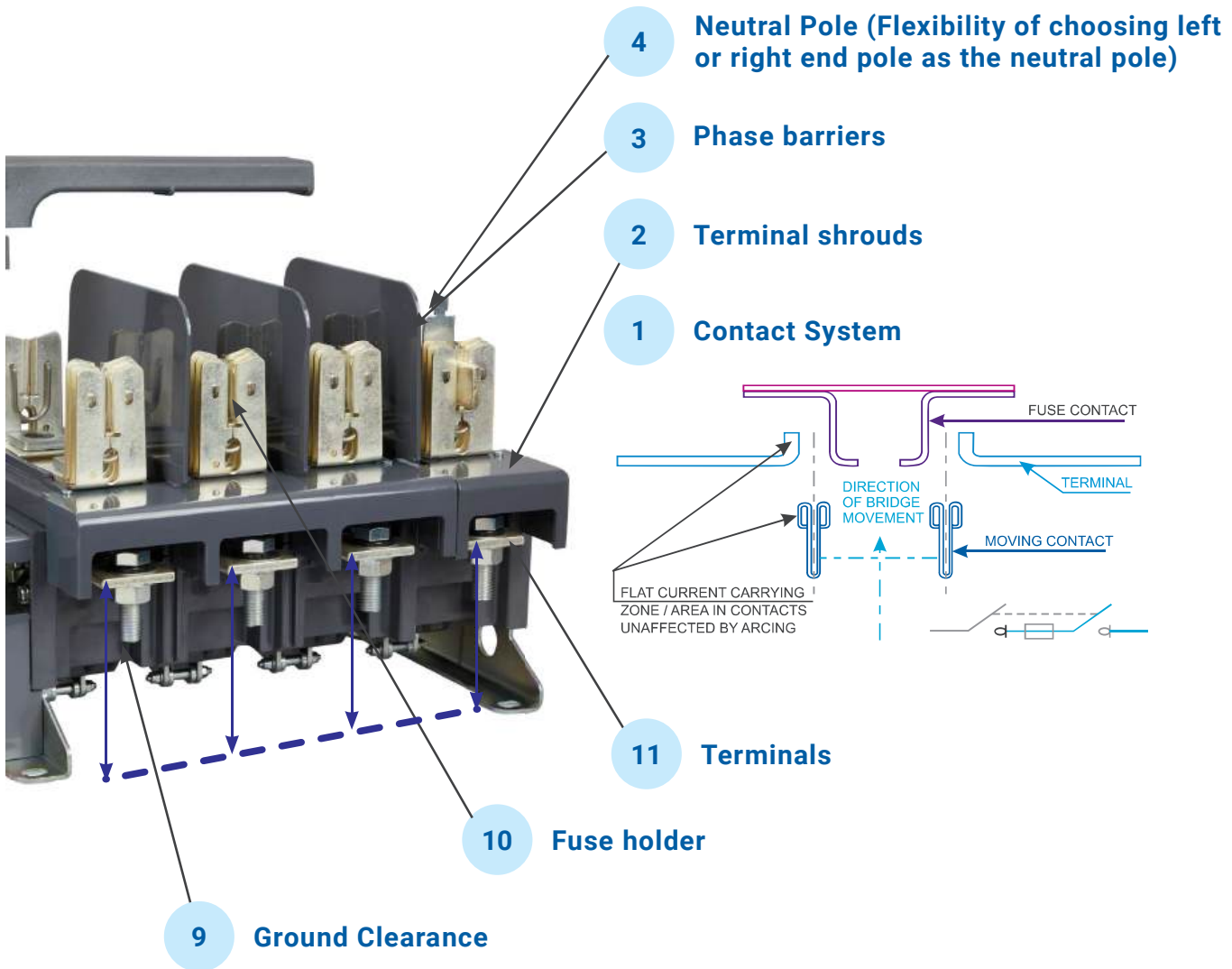

Convenience

- › Light Weight and Low Operating Torque
- › Compact design saves panel space
- › Clear ON / OFF indicator
- › Direct access to mounting & terminal screws
- › Generous terminal capacity
- › Suitable for vertical & horizontal orientation and can be mounted at any angle in a vertical plane
- › No load-line bias

Product Features

1. Contact System

Contact system is QUAD BREAK. There are no. of parallel moving contacts per pole per break resulting in better arc quenching & more electrical life of contacts. Each pole has separate bridge carrying the moving contacts, achieving a high order of interphase separation & avoiding phase-phase flash over.

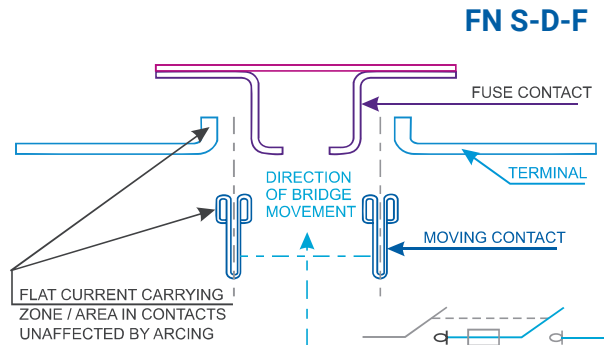

2. Terminal shrouds

The terminals are shrouded for protection against phase-phase short circuit through an external conducting path and also for protection against accidental human contact with live terminals.



3. Phase barriers

Interphase barriers are provided to eliminate the possibility of Interphase short circuit.



4. Neutral Pole

Switch-Disconnecter-Fuse consists of an integral neutral, making the units suitable for 3 phase, 4 - wire application.

› TPN SDF

FN 32 / 63 has switched neutral while higher ratings have isolable neutral.

› 4P SDF

4P FN SDFs have 100% rated switched neutral with in-built neutral isolating link



Flexibility of choosing left or right end pole as the neutral pole

5. Handle

The handle coupling has the following user-friendly features:

- › Easy fixing of handle on panel door by four screws.
- › Door interlock for safety of operating personnel when switch is 'ON'. The interlock can be defeated if required.
- › Built-in padlocking arrangement to lock the unit in either 'ON' or 'OFF' position.
- › The handle coupling is suitable for a mismatch or ± 3 mm in all directions.



6. Telescopic Shaft

Shaft length can be varied and adjusted as per requirement during installation. This is possible because the telescopic shaft can be adjusted for stepless variable depth.

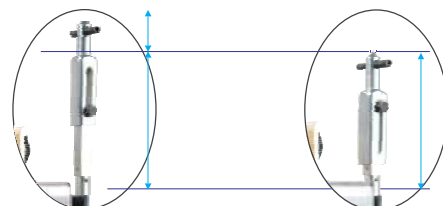

Product Features

7. ON / OFF indication

Clear ON / OFF indication is provided on the switch (by a red pointer). The position of the operating handle indicates the actual position of the main contacts inside the switch. The isolation position corresponds to the OFF position, in which padlocking is possible. However, in case of fault current if contacts get welded together and the handle shows intermediate position between ON and OFF, which clearly indicates supply is ON.

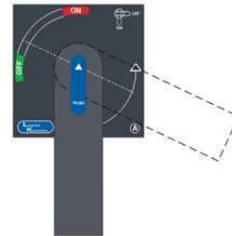

8. Mechanism

This mechanism is front operated quickmake /quick-break and independent of speed of operation.



9. Ground Clearance

Large ground clearance to eliminate possibility of phase-ground flash over.

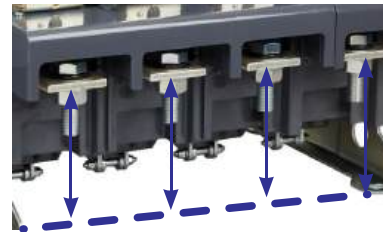

10. Fuse holder

Fuses remain stationary during switching operation. Fuses are isolated from both sides. This offers safety to operating personnel while replacing fuses.



11. Terminals

To accommodate both Aluminum & Copper cables & busbars.



Technical Specifications

| Frame Size | | I | | | |
|----------------------------------------------------------------------------------------------|-----------------------------------|-----------------|-------------------|-------------------|---------------------|
| Type Designation | Unit | FN 32 | FN 63 | FN 100 | |
| Reference standards | - | | | | |
| Neutral in TPN SDF | - | Switchable | Switchable | Isolable | |
| Rated operational voltage (Ue) | (V AC) | 415 | 415 | 415 | |
| Rated insulation voltage (Ui) | (V AC) | 690 | 690 | 690 | |
| Rated impulse withstand voltage (imp) | (kV AC) | 8 | 8 | 8 | |
| Rated frequency | (Hz) | 50 / 60 | 50 / 60 | 50 / 60 | |
| Service temperature | (OC) | -20 to 50 | -20 to 50 | -20 to 50 | |
| Pollution degree | - | 3 | 3 | 3 | |
| Conventional enclosed thermal current, I _{the} at 40°C | (A) | 32 | 63 | 100 | |
| Conventional free air thermal current, I _{th} at 40°C | (A) | 32 | 63 | 100 | |
| Rated operational current, I _e for AC 21A / AC 22A | (A) | 32 | 63 | 100 | |
| Rated operational current, I _e for AC 23A | (A) | 32 | 63 | 100 | |
| Rated breaking capacity (436 V, cosØ-0.35) | (A) | 256 | 504 | 800 | |
| Rated making capacity (436 V, cosØ-0.35) | (A) | 320 | 630 | 1000 | |
| Capacitor duty - 415 V 50 - 60 Hz | (kVAR) | 12 | 23 | 36 | |
| Mechanical endurance | (operating cycles) | 15000 | 15000 | 15000 | |
| Operating torque | (N-m) | 4 | 4 | 4 | |
| Auxiliary Contact Rated Current, I _{th} for AC-15 | Unit -A | 10 | 10 | 18 | |
| Terminations | | | | | |
| Terminal capacity (main) | mm ² | 35 | 35 | 95 | |
| Terminal capacity (neutral) | mm ² | 35 | 35 | 50 | |
| Terminal screw | mm | M6 x 12 | M6 x 12 | M8 x 20 | |
| DC Rating for DC 22B | | | | | |
| Rated operational current, I _e at 220 V DC (2P in series) | (A) | 32 | 63 | 100 | |
| Rated operational current, I _e at 440 V DC (3P in series) | (A) | 32 | 63 | 100 | |
| AC Rating for 690 V AC Operational Voltage | | | | | |
| Rated operational current, I _e for AC-22B | (A) | 32 | 63 | 63 | |
| Suitable L&T fuse | | | | | |
| DIN | Rated fused short circuit current | kA | 80** | 80** | 100 |
| | Rating | A / Type / Size | 32 / HF / 14 x 51 | 63 / HF / 14 x 51 | 100 / HN / 000 & 00 |
| BS | Rated fused short circuit current | kA | 80 | 80 | 80 |
| | Rating | A / Type / Size | 32 / HQ / A1L | 63 / HQ / A1L | 100 / HQ / A3 & A4 |
| *...Power factor = 0.45 as required in IEC 60947 -3 **...Suitable for cylindrical fuses | | | | | |

| II | | III | | IV | | V | |
|-----------------------------------------|---------------|---------------|--------------------|---------------|---------------|---------------|--------------|
| FN 125 | FN 160 | FN 200 | FN 250 | FN 315 | FN 400 | FN 630 | FN 800 |
| IEC 60947-3, EN 60947-3, IS/IEC 60947-3 | | | | | | | |
| Isolable | Isolable | Isolable | Isolable | Isolable | Isolable | Isolable | Isolable |
| 415 | 415 | 415 | 415 | 415 | 415 | 415 | 415 |
| 690 | 690 | 690 | 690 | 690 | 690 | 690 | 690 |
| 8 | 8 | 8 | 8 | 8 | 8 | 8 | 8 |
| 50 / 60 | 50 / 60 | 50 / 60 | 50 / 60 | 50 / 60 | 50 / 60 | 50 / 60 | 50 / 60 |
| -20 to 50 | -20 to 50 | -20 to 50 | -20 to 50 | -20 to 50 | -20 to 50 | -20 to 50 | -20 to 50 |
| 3 | 3 | 3 | 3 | 3 | 3 | 3 | 3 |
| 125 | 160 | 200 | 250 | 315 | 400 | 630 | 800 |
| 125 | 160 | 200 | 250 | 315 | 400 | 630 | 800 |
| 125 | 160 | 200 | 250 | 315 | 400 | 630 | 800 |
| 125 | 160 | 200 | 250 | 315 | 400 | 630 | 800 |
| 1000 | 1280 | 1600 | 2000 | 2520 | 3200 | 5040 | 6400 |
| 1250 | 1600 | 2000 | 2500 | 3150 | 4000 | 6300 | 8000 |
| 45 | 58 | 72 | 90 | 113 | 144 | 226 | 288 |
| 15000 | 15000 | 10000 | 10000 | 10000 | 10000 | 10000 | 10000 |
| 12 | 12 | 20 | 20 | 25 | 25 | 25 | 25 |
| 18 | 18 | 18 | 18 | 18 | 18 | 18 | 18 |
| | | | | | | | |
| 95 | 95 | 240 | 240 | 400 | 2 x 400 | 2 x 625 | 2 x 625 |
| 50 | 50 | 120 | 120 | 240 | 240 | 400 | 400 |
| M8 x 20 | M8 x 20 | M10 x 20 | M10 x 30 | M10 x 30 | M12 x 40 | M16 x 50 | M16 x 50 |
| | | | | | | | |
| 125 | 125 | 200 | 250 | 315 | 400 | 630 | 800 |
| 125 | 125 | 200 | 250 | 315 | 400 | 630 | 800 |
| | | | | | | | |
| 100 | 125 | 160 | 200 | 250 | 315 | 400 | 630 |
| | | | | | | | |
| 100 | 100 | 100 | 100 | 100 | 100 | 100 | 100 |
| 125 / HN / 000 & 00 | 160 / HN / 00 | 200 / HN / 0 | 250 / HN / 1 | 315 / HN / 1 | 400 / HN / 2 | 630 / HN / 3 | 800 / HN / 3 |
| 80 | 80 | 80 | 80 | 80 | 80 | 80 | |
| 125 / HQ / A4 | 125 / HQ / A4 | 200 / HQ / B2 | 250 / HQ / B2 & B3 | 315 / HQ / B3 | 400 / HQ / B4 | 630 / HQ / C2 | |

Altitude derating chart for FN & COS

| De-rating at different altitudes for SD/SDFs & COS | | | | | | | |
|----------------------------------------------------|-----------|------|-----------|---------------|---------------|---------------|--------------|
| Altitude | Height | (m) | at 2000 | 3000 | 4000 | 5000 | 6000 |
| Rated operational voltage | U_e | (V) | 415 | 374 | 332 | 291 | 249 |
| Rated operational current | I_e | (A) | I_e | $0.98I_e$ | $0.96I_e$ | $0.94I_e$ | $0.92I_e$ |
| Conventional enclosed thermal current | I_{the} | (A) | I_{the} | $0.91I_{the}$ | $0.81I_{the}$ | $0.76I_{the}$ | $0.7I_{the}$ |
| Impulse withstand voltage | U_{imp} | (kV) | 8 | 7.2 | 6.4 | 5.6 | 4.8 |
| Impulse withstand voltage | U_{imp} | (kV) | 12 | 10.8 | 9.6 | 8.4 | 7.2 |
| Rated insulation voltage | U_i | (kV) | 690 | 621 | 522 | 483 | 414 |
| Rated insulation voltage | U_i | (V) | 1000 | 900 | 800 | 700 | 600 |

Selection Of Handle

FN switch range offers a distinctive feature to mount S-D-F in different quadrants.

This feature aids mounting flexibility.

Handle coupling is as per IS 8623.

FN S-D-F operating quadrant chart

(Seen from front of the door) In FN Switch universal mounting is achieved by Type A and Type B handle.

Type A : Supplied as standard with all Switches

Type B : Available as an accessory

Seen from front of the door

| Sr. No. | Handle (OFF) Position | Operating Quadrant (hand) | Switch Orientation | Door Cut-out | Handle Coupling Type |
|---------|-----------------------|---------------------------|--------------------|--------------|----------------------|
| 1 | | | | | A |
| 2 | | | | | B |
| 3 | | | | | B |
| 4 | | | | | A |
| 5 | | | | | A |
| 6 | | | | | B |
| 7 | | | | | B |
| 8 | | | | | A |

Ordering Information

FN S-D-F Ordering Information

| Operating Current Rating (A) | 32 | 63 | 100 | 125 |
|-----------------------------------------------------|-----------------------------|-----------------------------|-------------|-------------|
| TP SDF with DIN type fuses | ST278920000 | ST278930000 | ST302870000 | ST350870000 |
| TPN SDF with DIN type fuses | SK955180000 SK957030000* | SK954210000 SK957030000* | SK955680000 | SK950010000 |
| 4P SDF with DIN type fuses | SK955180000 SK957030000* | SK954210000 SK957030000* | SK904960000 | SK904970000 |
| TPN SDF with bolted type fuses | SK956530000 | SK956510000 | SK955700000 | SK950090000 |
| TPN SDF with bolted type fuses (suitable for HE) | SK901330000 | SK901340000 | - | SK900690000 |
| TPN SDF in spacious SS enclosure | SK904830000 | SK904840000 | SK904850000 | SK904860000 |

| Operating Current Rating (A) | 160 | 200 | 250 | 315 |
|-----------------------------------------------------|-------------|-------------|-------------|-------------|
| TP SDF with DIN type fuses | SK959980000 | ST278950000 | ST317310000 | ST278970000 |
| TPN SDF with DIN type fuses | SK957130000 | SK954180000 | SK956420000 | SK954610000 |
| 4P SDF with DIN type fuses | SK904980000 | SK904710000 | SK904720000 | SK904730000 |
| TPN SDF with bolted type fuses | SK957140000 | SK955880000 | SK956820000 | SK955900000 |
| TPN SDF with bolted type fuses (suitable for HE) | SK901300000 | SK904160000 | SK904170000 | SK901320000 |
| TPN SDF in spacious SS enclosure | SK904870000 | SK904880000 | SK904890000 | SK904900000 |

| Operating Current Rating (A) | 400 | 630 | 800 |
|-----------------------------------------------------|-------------|-------------|-------------|
| TP SDF with DIN type fuses | ST278980000 | ST278990000 | ST279000000 |
| TPN SDF with DIN type fuses | SK954810000 | SK955210000 | SK956790000 |
| 4P SDF with DIN type fuses | SK904800000 | SK904810000 | SK904820000 |
| TPN SDF with bolted type fuses | SK955910000 | SK955920000 | - |
| TPN SDF with bolted type fuses (suitable for HE) | SK900990000 | SK901280000 | - |
| TPN SDF in spacious SS enclosure | SK904910000 | SK904920000 | SK904930000 |

* 'CE' handle has door interlock facility without defeat feature

Spares and Accessories

Wide range of spares & accessories are available for Switch-Disconnecter units

Type FN Spares & Accessories



Terminal Shroud

The terminals can be shrouded for protection against phase-short circuit through an external conducting path and against accidental human contact with live terminals.

FN SDF are now fitted with terminal shrouds on both input & load side.



Castell interlock

Switch-Disconnecter-Fuse units can be locked on OFF position with help of castell interlock. Castell interlock can also be used to interlock two SDF units. (Different variety of locks are available).



Handle coupling (type A & B)

Irrespective of the switch orientation (vertical or horizontal), operation in any of the four quadrants is possible by selecting right handle coupling (Refer Handle selection table).



Auxiliary contacts

1 NO + 1 NC auxiliary contact is available as an accessory. Also, 2NO + 2NC can be obtained by using additional 1NO + 1NC. This can be suitably wired in the control circuit.

- › Rated operational current I_e (AC - 15) - 4 A
- › Rated operational voltage U_e - 415 V



Fuse Puller

A fuse puller is provided to facilitate easy & safe removal of fuses.



Earthing Assembly

The site-mountable earthing assembly facilitates termination of 25 mm wide earthing bar

Type FN Spares & Accessories

| Description | FN 32 / 63 | FN 100/125/160 | FN 200 | FN 250 | FN 315 | FN 400 | FN 630 | FN 800 |
|--------------------------------|---------------|---------------------------|-------------|--------|---------------------------|--------|-------------|--------------|
| Terminal Shroud Kit | SK911900000 | SK913280000 | SK913350000 | | SK913460000 | | SK913470000 | |
| Aux. Contact (1 NO + 1 NC) | SK913020000 | SK912580000 | SK913290000 | | SK913300000 | | | CK9103400000 |
| 2nd Aux. Contact (1 NO + 1 NC) | SK906700000 | SK906960000 | | | | | | |
| Handle Coupling (Type - A) | SK912570000 | SK912580000 | SK912580000 | | SK912590000 | | SK912590000 | |
| Handle Coupling (Type - B) | SK912770000 | SK912780000 | SK912780000 | | SK912790000 | | SK912790000 | |
| Handle Coupling (Type - CE) | SK913370000 | Not Available | | | | | | |
| Fuse Puller | SK911850000 | SF901260000 | | | SK912790000 | | | |
| Castell Lock (Type A-Type D) | Not Available | SK003330000 - SK003360000 | | | SK003450000 - SK003480000 | | | |
| Earthing Assembly | - | CK903960000 | | | | | | |

Ordering Suffix - 0000 for all.

HRC Fuses

High Rupturing Capacity Fuse Link - Technical Note

Introduction:

A fuse is a piece of conducting element which is designed to carry rated current in normal conditions and breaks the circuit by rupturing/melting under overload or short circuit faults. Fuse-links are current sensitive devices.

Construction:

A HRC type fuse link typically consists of a fuse element welded in between the blade contacts and enclosed in an insulating tubular fuse body. The blade contacts are placed between cover plates with protruding gripping-lugs which engage with the fuse pulling handle for easy removal of the fuses. An indicating device - flap indicator is fixed to the face end and is released when the fuse blows.

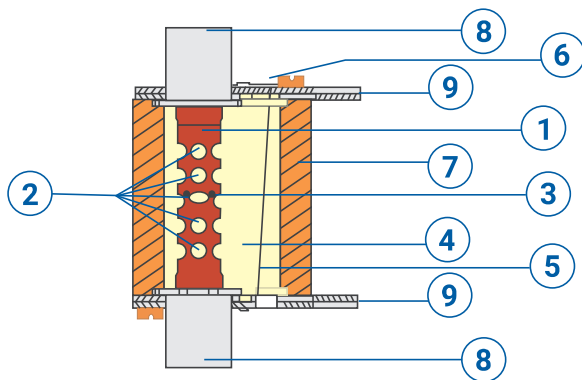

1. Fuse Element
2. Notches / constrictions
3. M-effect solder
4. Filler
5. Indicator Wire
6. Indicator Button
7. Fuse body
8. Fuse blade contact/knife
9. End Plate

- › The fuse-element is the vital component of the HRC fuse which determines the overall performance of the fuse link. It is made of copper strip, and manufactured with utmost care and precision. Uniform strip thickness, good conductivity and a precise neck profile ensures low power dissipation. One peculiarity of the fuse element is presence of constrictions at regular intervals which heat up rapidly when abnormal/short circuit flows and start rupturing. The number of constrictions / notches in series is dependent on the recovery voltage (system voltage). Approximately one constriction per 90V is required.
- › The insulation body is designed to withstand very high temperatures and internal pressure. It is made of high-quality ceramics and prevents the ejection of hot gases and liquid metal into the environment.
- › The cover / end plates are provided with gripping lugs intended to be engaged with the standardized replacement handle (fuse pulling handle) for safe insertion and removal of the fuse-link. Along with the ceramic body, these form a pressure-resistant casing for the switching arc.
- › Crystal quartz sand of high chemical and mineralogical purity (SiO_2 content $> 99.5\%$) is generally used. It is completely anhydrous as a result of heat-drying. Sand is important for achieving current limitation as it absorbs the arc energy and pressure generated. A defined grain size distribution and optimum packing density are essential for the performance. It effectively dissipates energy from the arc column by fusion.
- › The indicating device allows quick detection of blown fuses.
- › The solder is an element which has lower melting point and is chosen specially to react with the material of the fuse-element. It causes the time current characteristic to be shifted to lower melting currents thereby giving protection against overload condition. The quantity and placement of the solder element is crucial for its effective functioning.
- › The blade contacts are designed to electrically and mechanically connect the fuse link with the fuse base/Switch Fuse Disconnecter. These are made of copper or copper alloy, the contact surface is generally silver-plated.

HRC Fuses

Fuse works on simple principle of heat generation (I^2t) by the amount of current flowing.

The constrictions on the cross-section of the fuse element are the weakest links in a HRC fuse. These are designed to heat up faster and reach higher temperatures than any other part of the fuse.

When an over current flows for a period long enough to cause the restrictions to melt, current paths breaks which results in development of an arc. Fuse elements made of pure copper are suitable for breaking high over current only (heat energy generated is I^2t) as the melting temperature is 1080°C .

In case, the melting temperature is reached at extremely slow rate, the fuse link becomes extremely heated, which may result in glowing contacts or destroying adjacent equipment components. Therefore, for fuse elements without any additional low-melting point material, there is always a called "prohibited" current range allowing the elements to be used only in partial range fuses for short-circuit protection.

Utilization Category of HRC fuse:

The area of application is designated by two letters, the first of which specifies the breaking current range and the second the utilization category.

| Letter Code | Application (Characteristic) | Breaking Range |
|-------------|-----------------------------------------------------------|----------------|
| gG | General Purpose fuse-link mainly for conductor protection | Full range |
| gM | Motor circuit Protection | Full range |
| aM | Short - circuit Protection of motor circuits | Partial range |

- › The letter "g" indicates full-range fuses that can continuously conduct currents at least up to their rated current I_n and that can break currents from the smallest melting current up to the rated breaking current.
- › The letter "a" signifies partial range fuses that can continuously conduct currents at least up to their rated current I_n and that can break currents above of a certain multiple of their rated current up to the rated breaking current. Generally, the breaking range begins at over four times the rated current and hence these are solely designed for short-circuit protection.
- › Our HF, HN and HG fuses have gG utilization category.

Overload disconnection

For disconnection of smaller over currents, a low-melting-point solder consisting usually of tin or tin alloy is applied on to the centre constriction wherein the fuse-element reaches its highest temperature. As the solder melts, the adjacent restrictions are dissolved and an arc is initiated which continues in both directions. At subsequent current zero, the arc is extinguished.

Intensive cooling of the arc channel caused by the melting quartz sand prevents re-ignition of the arc when the recovery voltage appears. In the arcing area a non-conductive mixture composed of fuseelement metal, solder and quartz is formed. Due to its appearance, it is also called "fulgurite caterpillar".

At very high currents, all constrictions melt almost simultaneously, thereby initiating development of several partial arcs depending on the number of constrictions and forming a fulgurite uniformly extended over the whole length of the fuse-element which is typical for short-circuit interruptions.

HRC Fuses

Current-limiting short-circuit disconnection

At very high currents, like caused by short circuits, all constrictions heat up simultaneously at a speedy rate and the fuse element starts evaporating.

If the sand is packed too tightly packed with minute dust particles, extreme high pressure is built inside the fuse which can cause bursting of the fuse body. If the interspatial volume between the grains is too large, the arc can extend up to the

inside ceramic surface of the fuse body or the end plates and cause damage the fuse body. Properly graded and carefully prepared sand will intensively cool the arc due to its energy absorbing ability, with the result that when the arcing voltage exceeds the supply voltage, the current is already terminated before natural zero of a 50 / 60 Hz alternative current. The peak value of the prospective short-circuit current is not reached at all.

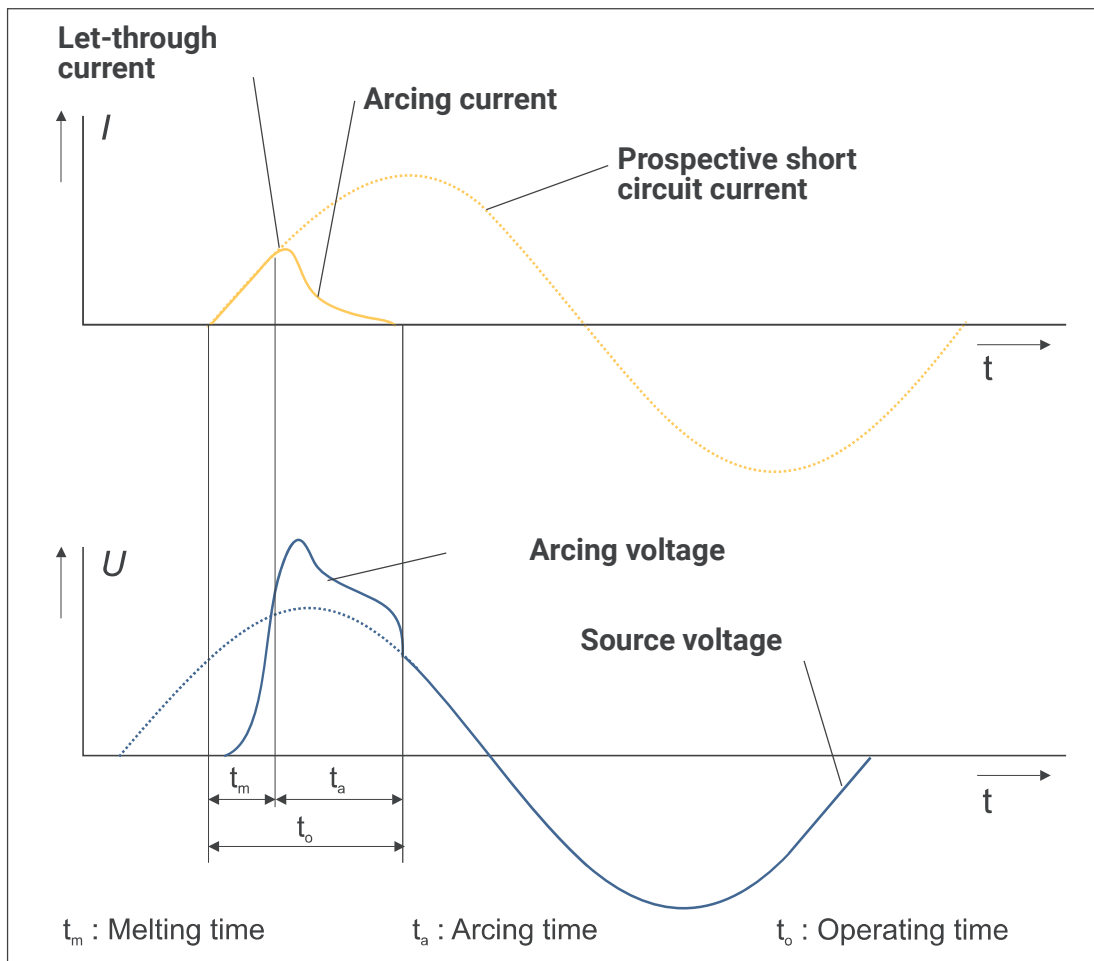

Therefore, its current-limiting effect is one of the most valuable properties of the fuse, making it superior to any other over current protection device. Short-circuit usually has a very high first peak value known as impulse short-circuit current. Its magnetic force effect causes extraordinary stress to the current-carrying conductors, related clamps and insulation. Using current-limiting fuses help in keeping magnetic short-circuit forces at a low level and allows to easily control them.

Current-limiting fuses are designed to significantly limit not only the maximum current, but also the let-through energy, expressed in I^2t values, which occurs, for example, in the case of an arc fault, where a destructive energy is released at the fault location.

Thus, current limitation is synonymous with limitation of damage and risk to personnel working in live condition.

HRC Fuses

Current limitation & Selectivity of fuse as Short circuit protection device

In buildings and industrial plants, radial distribution networks are the norm. In radial distribution systems there are several protective devices in series, usually with decreasing rated currents from the supply end to the load end. While the operational currents decrease from the supply end to the load end, in the event of a short circuit the same fault current will flow through all the protective devices connected in series. By cascading of the trip characteristics it must be ensured that only the respective protective device that is closest to the location of the fault trips and hence the fault is selectively limited to the smallest possible part of the installation.

The basic prerequisite for selectivity of protective devices connected in series is that the trip characteristic of the downstream (closer to the load) protective device is faster than that of the upstream device. Special attention should be paid to the area of high over currents, where the effects of current limitation and breaking times are significant.

This Cascading & selectivity for the fuses is very simple because of the similarity in the characteristics throughout the range & constant characteristics for complete life of fuse.

Connection of fuses in series

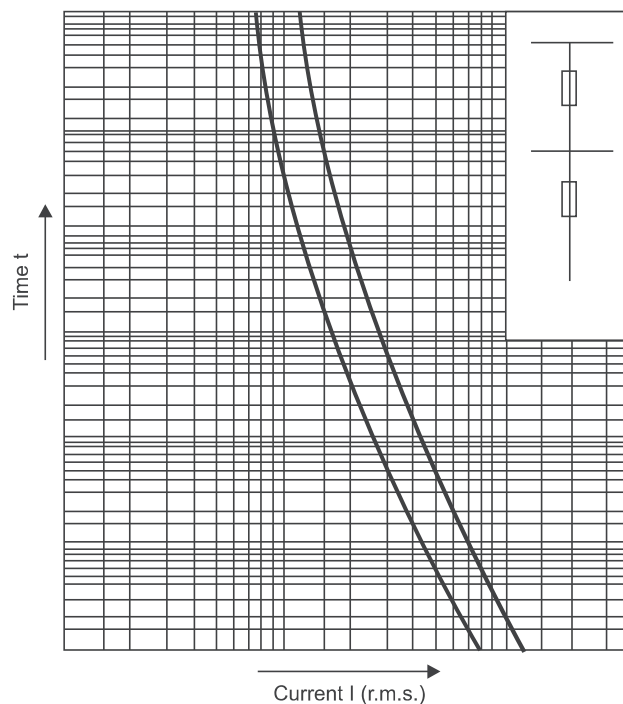

Fuses connected in series act selectively if their time-current-characteristic curves have sufficient spacing and their tolerance bands do not touch. At high short-circuit currents the melting I^2t value of the upstream fuse must be larger than the breaking

I^2t value (melting and clearing time) of the smaller downstream fuse. This is usually the case if their rated currents differ by a factor of 1.6 or more

HRC Fuses

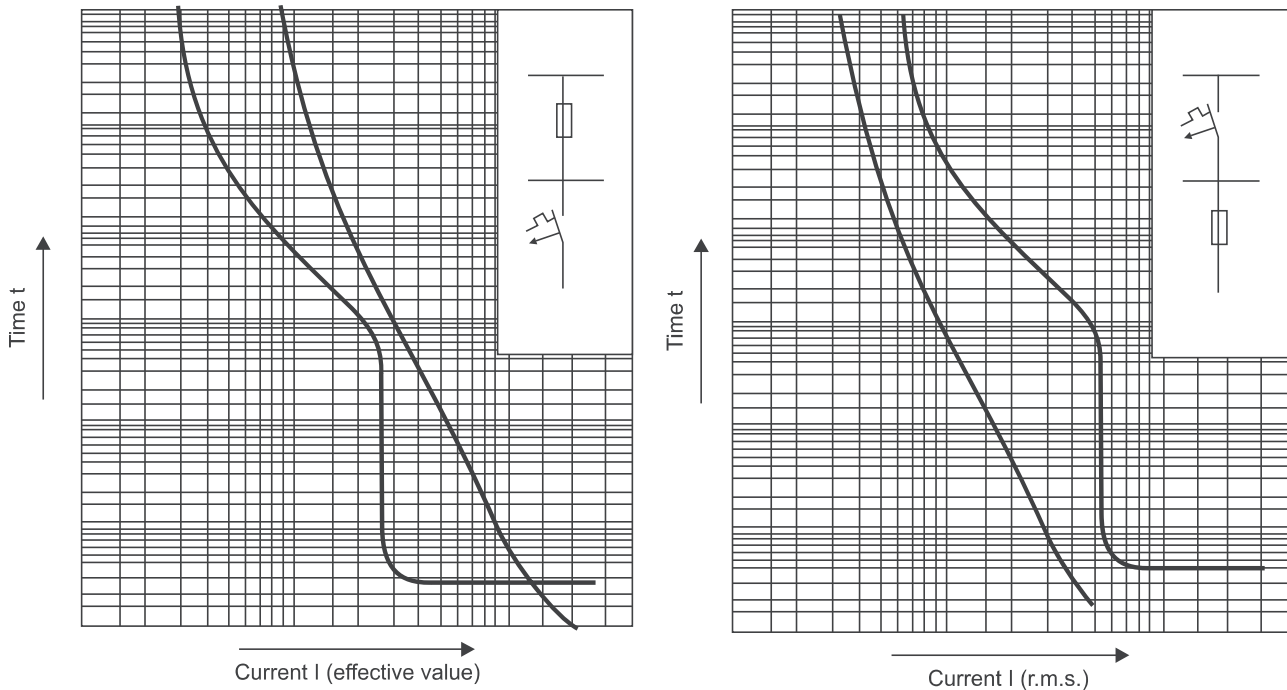

Connection of fuse & circuit breaker in series

1. Circuit breaker 2. Fuse

When fuse is installed as a downstream device, co-ordination between the tripping range of the short-circuit release of the circuit breaker and cut of current of the fuse can be seamlessly achieved as the short circuit currents are interrupted instantaneously by the fuse.

E&A HRC fuses Power loss data

| Size | Rating | Permitted power loss IS/IEC standard) W | Rated Power loss (W) HN fuse link | % saving in electricity consumed |
|------|--------|-----------------------------------------|-----------------------------------|----------------------------------|
| 000 | 100 | 7.5 | 7 | 7% |
| 0 | 160 | 16 | 12.7 | 21% |
| 1 | 250 | 23 | 17.3 | 25% |
| 2 | 400 | 34 | 24.9 | 27% |
| 3 | 630 | 48 | 42.2 | 12% |

Get the Fuse advantage!

- › Let-through energy value of fuse is extremely low compared to circuit breaker
- › Low let-through energy leads to low stresses to the down stream protection devices & equipment
- › Optimal cable size & contactor rating in case of type two co-ordinations due to low I^2t value.
- › Low power loss leads to low running cost & minimum heating.

HRC Fuses - Cylindrical

HRC Fuses - Cylindrical

Fuse Links Type HF

(Fuse links with cylindrical contact caps)

- › Conforms to IEC 60269-2, IS 13703-2
- › Low watt loss - Saves power
- › Low let through energy
- › High breaking capacity - 80 kA
- › Rated voltage - 415 V
- › Instant fault indication through red pop up indicator
- › Lower power loss in our fuses result in cooler running of associated products



Ordering Details

| Size of the Fuse Link | Rating (A) | Description | Cat. Nos. | Rated Watt Loss (W) | Watt Loss Limits as per IS 13703 (W) | Suitable for S-D-F units type FN/ FNX or Equivalent |
|-----------------------|------------|-----------------------------------------------------------------------------|---------------------|---------------------|--------------------------------------|-----------------------------------------------------|
| Size 14 X 51 | 2 | Suitable for Type FN 32 / 63 / FNX 32 / 63 S-D-F. Also for HCO 32 Fuse base | SF90144 | 100 Amp, Fuse 7.5 W | 5 | 32, 63 |
| | 4 | | SF90145 | | | 32, 63 |
| | 6 | | SF90146 | | | 32, 63 |
| | 8 | | SF90147 | | | 32, 63 |
| | 10 | | SF90148 | | | 32, 63 |
| | 16 | SF90150 | 100 Amp, Fuse 7.5 W | 7 | 32, 63 | |
| | 20 | SF90151 | | | 32, 63 | |
| | 25 | SF90152 | | | 32, 63 | |
| | 32 | SF90142 | | | 32, 63 | |
| | 40 | SF90143 | | | 63 | |
| | 50 | Also for HC 63 Fuse base | SF90158 | | | 63 |
| | 63 | | SF90159 | | | 63 |

Fuse-pulling handle should be used for safe and easy removal of fuse links
 Suitable fuse - pulling handle for type HF : SK91185

HRC Fuses - Blade / Knife type

Fuse Links Type HN

(Fuse links with blade contacts)

- › Conforms to IEC 60269-2, IS 13703-2
- › Low watt loss - Saves power
- › Cooler running of associated products
- › Low let through energy
- › High breaking capacity - 100 kA
- › Instant fault indication
- › Rated voltage - 415 V



Ordering Details

| Size of the Fuse Link | Rating (A) | Cat. Nos. | Rated Watt Loss | Watt Loss Limits as per IS 13703 | Suitable for S-D-F units type FN/FNX or Equivalent |
|-----------------------|------------|-----------|-----------------|----------------------------------|----------------------------------------------------|
| Size 000 | 63 A | SF94940 | 5.3 | 100 Amp, Fuse 7.5 W | 100,125,160 |
| | 80 A | SF94941 | 6.2 | | 100,125,160 |
| | 100 A | SF94942 | 7 | | 100,125,160 |
| | 125 A | SF94946 | 8.5 | | 100,125,160 |
| Size 00 | 63 A | SF94027 | 5.7 | 100 Amp, Fuse 7.5 W | 100,125,160 |
| | 80 A | SF94028 | 6.9 | | 100,125,160 |
| | 100 A | SF94029 | 7.5 | | 100,125,160 |
| | 125 A | SF94030 | 9.8 | | 125,160 |
| | 160 A | SF94939 | 12 | | 160 |
| Size 0 | 80 A | SF94128 | 8.3 | 160 Amp, Fuse 16 W | 200 |
| | 100 A | SF94129 | 9.1 | | 200 |
| | 125 A | SF94130 | 11.3 | | 200 |
| | 160 A | SF94131 | 12.7 | | 200 |
| | 200 A | SF94132 | 14.5 | | 200 |
| Size 1 | 125 A | SF94230 | 10.3 | 250 Amp, Fuse 23 W | 250, 315 |
| | 160 V | SF94231 | 12.3 | | 250, 315 |
| | 200 A | SF94232 | 14.3 | | 250, 315 |
| | 250 A | SF94233 | 17.3 | | 250, 315 |
| | 315 A | SF94234 | 25.5 | | 315 |
| Size 2 | 200 A | SF94332 | 14.1 | 400 Amp, Fuse 34 W | 400 |
| | 250 A | SF94333 | 16.9 | | 400 |
| | 315 A | SF94334 | 20.2 | | 400 |
| | 400 A | SF94335 | 24.9 | | 400 |
| Size 3 | 315 A | SF94434 | 20.5 | 630 Amp, Fuse 48 W | 630, 800 |
| | 400 A | SF94435 | 26.7 | | 630, 800 |
| | 500 A | SF94436 | 36.1 | | 630, 800 |
| | 630 A | SF94437 | 42.2 | | 630, 800 |
| | 800 A | SF94938 | 48 | | 800 |

Fuse-pulling handle should be used for safe and easy removal of fuse links
Suitable fuse - pulling handle for type HN : SF90126

HRC Fuses - Bolted

Fuse Links Type HG and HQ

(Fuse links for bolted connections)

- › Conforms to IEC60269 / IS 13703-2
- › Low watt loss
- › Low let through energy
- › High breaking capacity - 80kA
- › Rated voltage - 415V



Type HQ & Type HG

| Fixing Method | Size | Rating (A) | Description | Cat. No. | Power loss (W) | Watt loss limits as per IS 13703 |
|-------------------|---------|-------------------------------------------------------------------------------------------------|----------------------------------------------------------|----------|--------------------------------------------------------------------------------------|----------------------------------|
| Offset, Staggered | F1 | 2 | Suitable for type HD20H/20P/20B, HD32H/32P/32B Fuse base | ST30725 | 0.3 | 32 A, Fuse - 3.2W |
| | | 4 | | ST30726 | 0.5 | |
| | | 6 | | ST30727 | 1.2 | |
| | | 10 | | ST30728 | 1.4 | |
| | | 16 | | ST30729 | 1.8 | |
| | | 20 | | ST30730 | 2.2 | |
| | | 25 | | ST30731 | 2.9 | |
| | | 32 | | ST30732 | 3.0 | |
| Offset | A1 | 2 | - | ST30736 | 0.3 | 20 A, Fuse - 2.7W |
| | | 4 | | ST30737 | 0.5 | |
| | | 6 | | ST30738 | 1.2 | |
| | | 10 | | ST30739 | 1.4 | |
| | | 16 | | ST30740 | 1.8 | |
| | | 20 | | ST30741 | 2.2 | |
| | | 25 | | ST30742 | 2.9 | |
| | | 32 | | ST30743 | 3.0 | |
| | A1L | 20 | Suitable for type FN32/63 Switch disconnecter Fuse unit | ST30527 | 2.4 | 20 A, Fuse - 3.2W |
| | | 25 | | ST30528 | 3.1 | |
| | | 32 | | ST30529 | 3.4 | |
| | | 50 | | ST30827 | 4.0 | |
| | A2 | 4 | Suitable for type HK32H/32B Fuse base | ST30747 | 0.8 | 32A, Fuse - 4.4W |
| | | 6 | | ST30748 | 1.4 | |
| | | 10 | | ST30749 | 1.5 | |
| | | 16 | | ST30750 | 2.0 | |
| | | 20 | | ST30751 | 2.8 | |
| | | 25 | | ST30752 | 3.8 | |
| | | 32 | | ST30753 | 4.4 | |
| | | A3 | | 35 | Suitable for type FN 100 Switch disconnecter Fuse unit, also for HK63B/63H Fuse base | |
| 50 | ST30760 | | 6.2 | | | |
| 63 | ST30761 | | 6.8 | | | |
| A4 | 80 | Suitable for type FN100/120/160 Switch disconnecter Fuse unit, also for HK 125H//125B Fuse base | ST30767 | 9.1 | 100 A, Fuse - 9.1W | |
| | 100 | | ST30768 | 9.5 | | |
| | 125 | | ST30769 | 14 | | |
| | 160 | | ST30829 | - | | |

Characteristic Curves

HRC Fuse-link Type HF

› Time-Current Characteristics

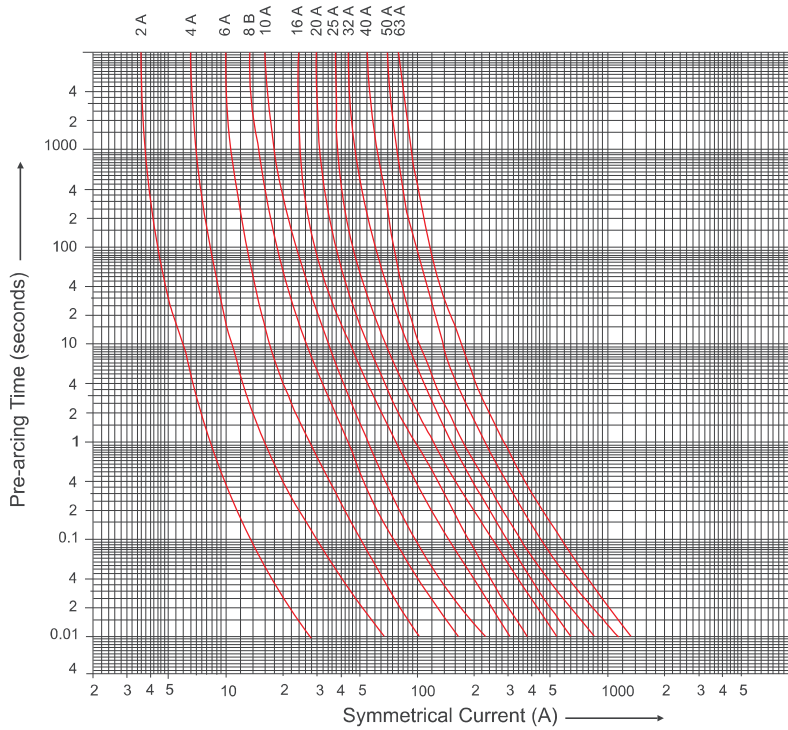

› Cut-off Current Characteristics

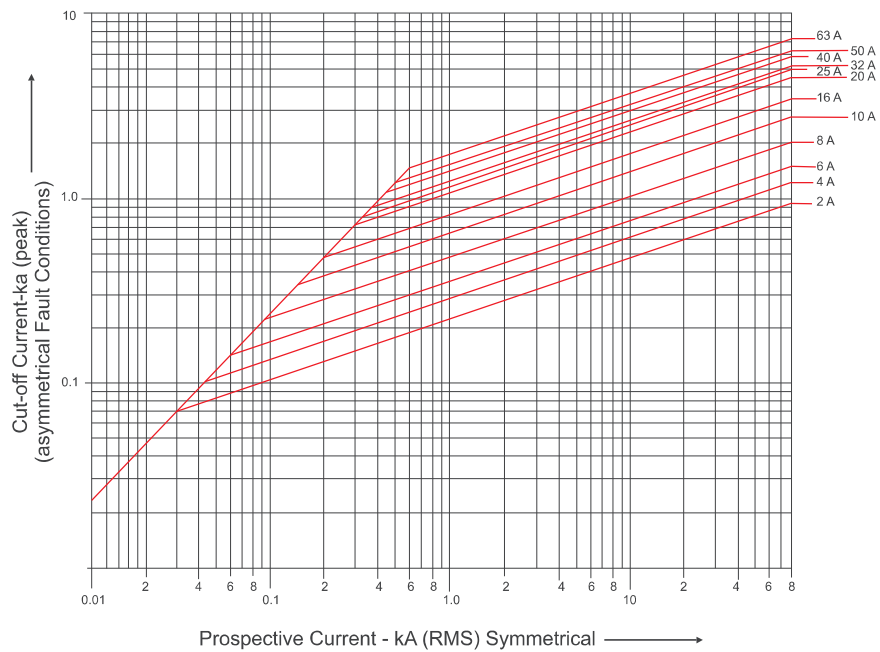

Characteristic Curves

HRC Fuse-link Type HN

› Time-Current Characteristics

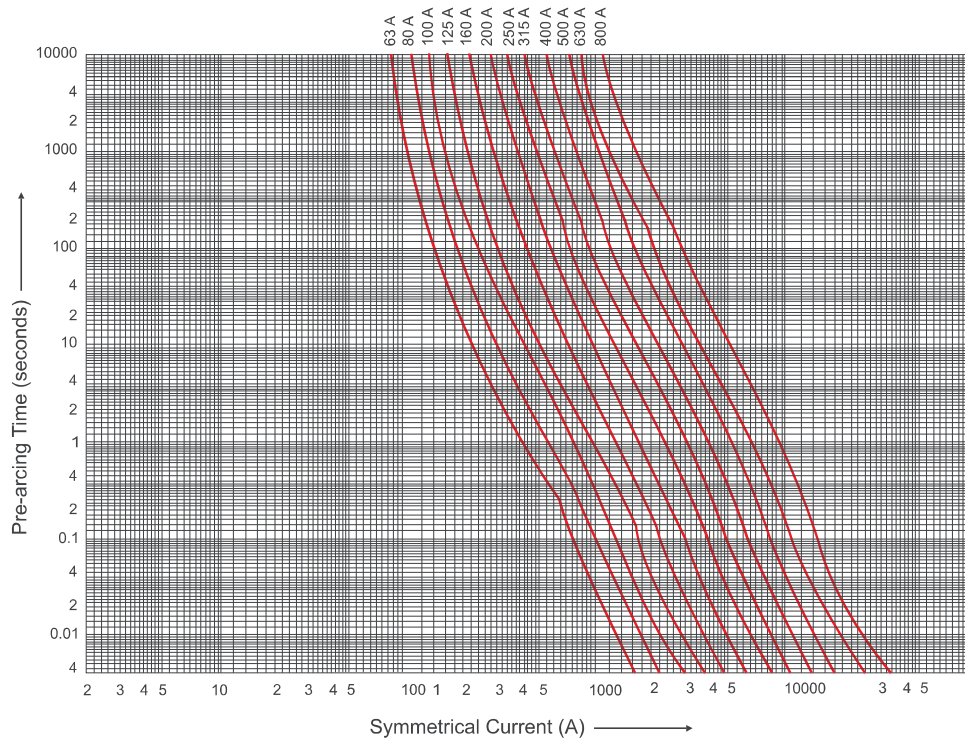

› Cut-off Current Characteristics

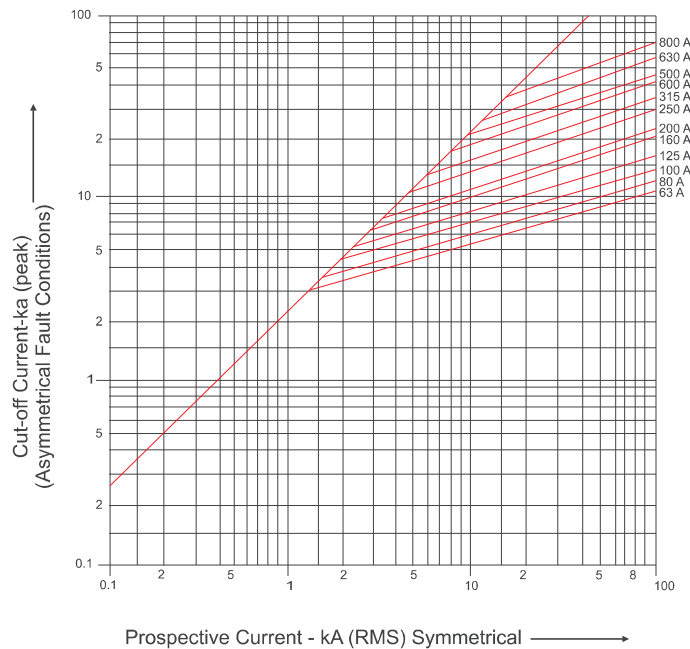

Characteristic Curves

HRC Fuse-link Type HQ

› Time-Current Characteristics

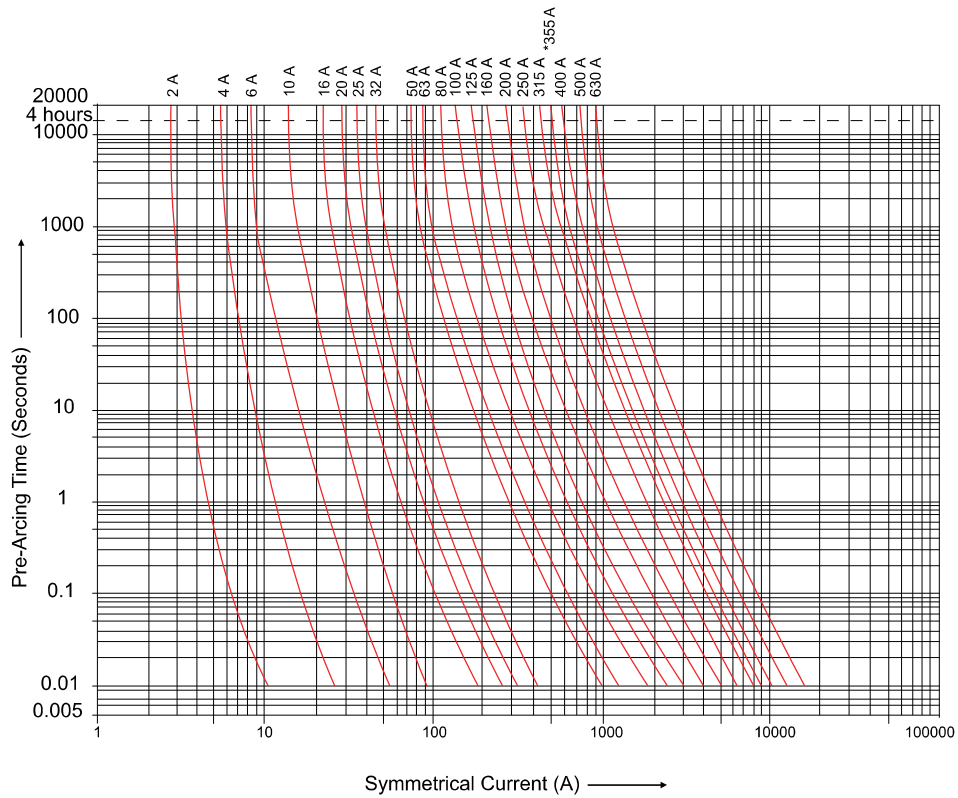

› Cut-off Current Characteristics

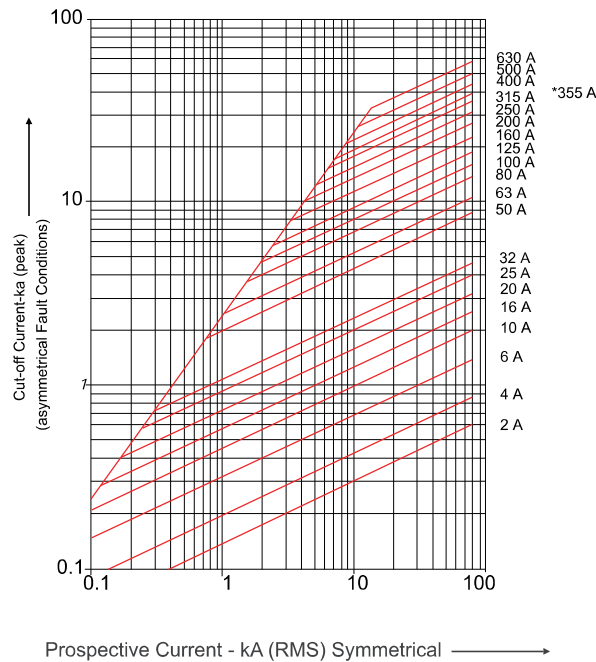

Overall Dimensions FN 32 / 63

Switch-Disconnecter-Fuse
(suitable for DIN type fuses)

› SDF - FN 32 / 63 2P

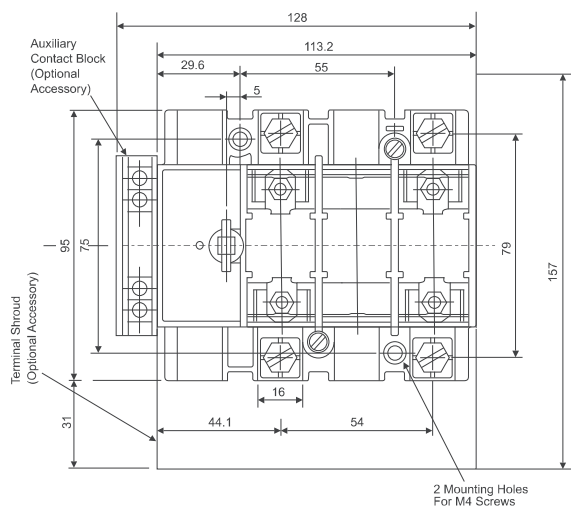
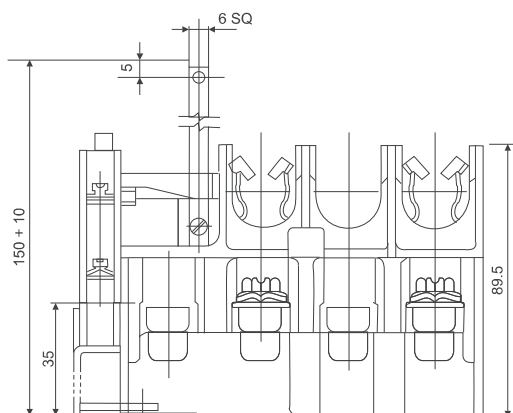

› SDF - FN 32 / 63 TPN

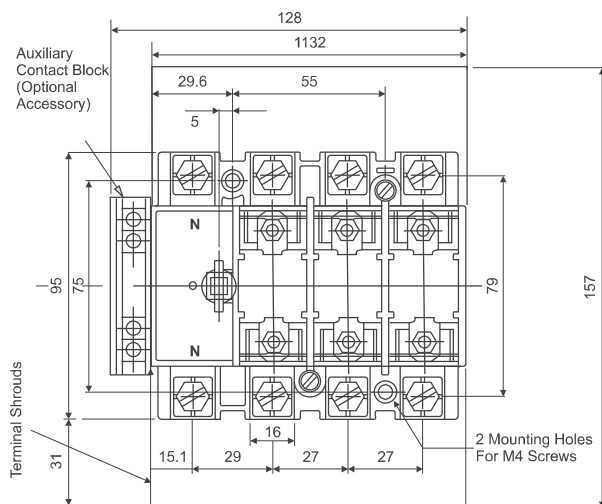
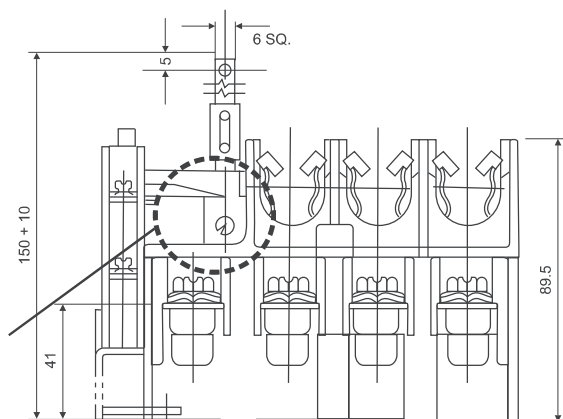

Note : All dimensions are in mm.

Overall Dimensions FN 32 / 63

Switch-Disconnecter-Fuse (suitable for Bolted type fuses)

› SDF - FN 32 / 63 TPN

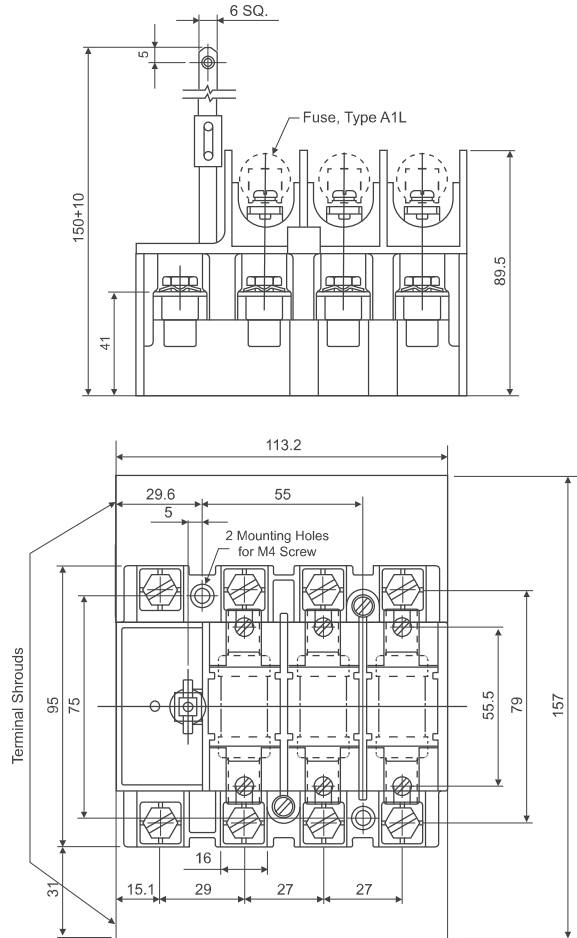

› Assembly of Handle Coupling on Door - FN 32 / 63

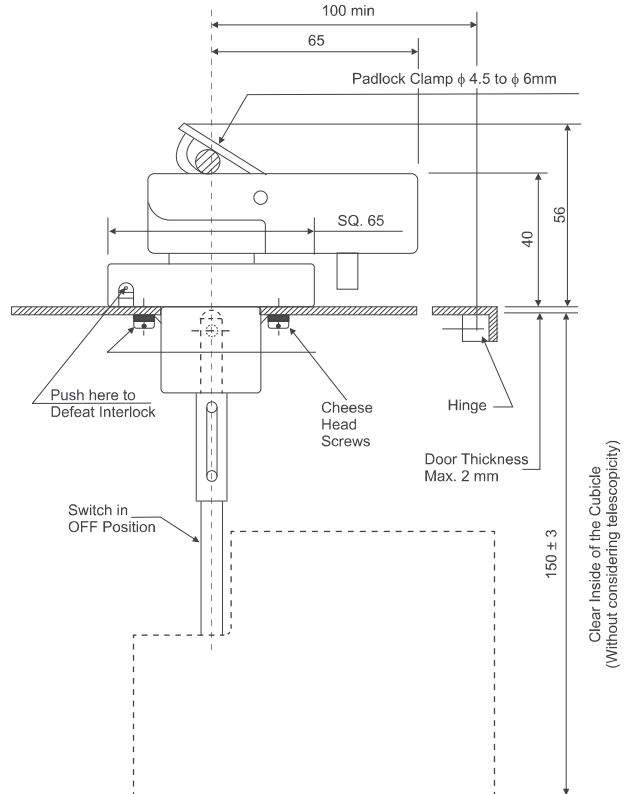

› Drilling details FN 32 / 63

**Drilling details on door
for mounting handle coupling
seen from front of the door**

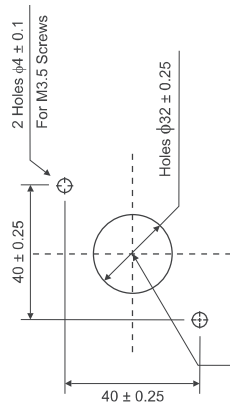

**Drilling details on base plate
for mounting switch
seen from front of the door**

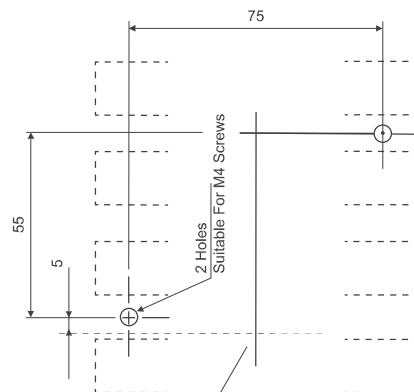

Mismatch ± 3 Permissible

Operating Shaft Center

Note : All dimensions are in mm.

Overall Dimensions FN 100 / 125 / 160

› SDF - FN 100 / 125 4P

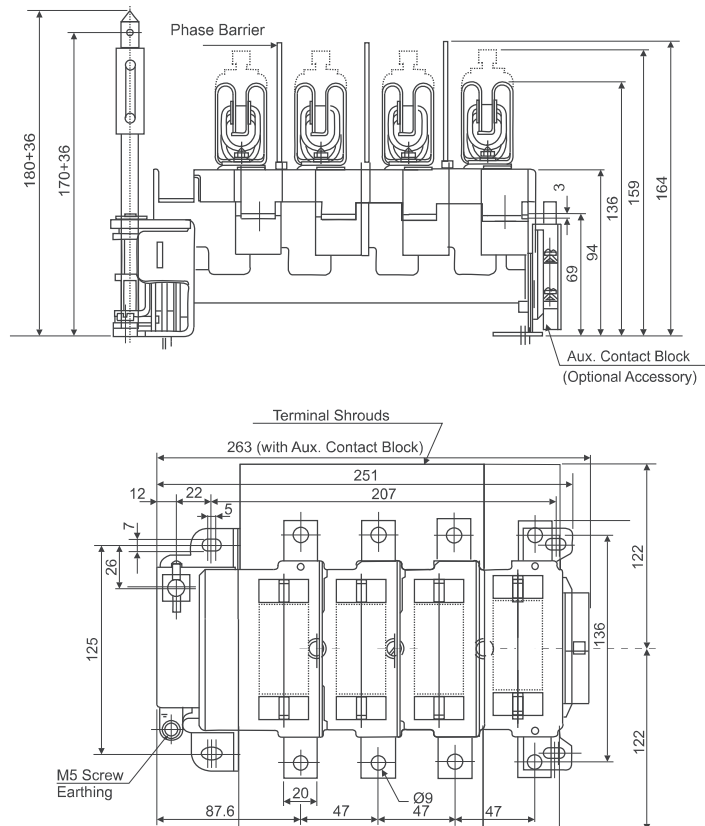

Switch-Disconnecter-Fuse (suitable for DIN type fuses)

› SDF - FN 160 2P

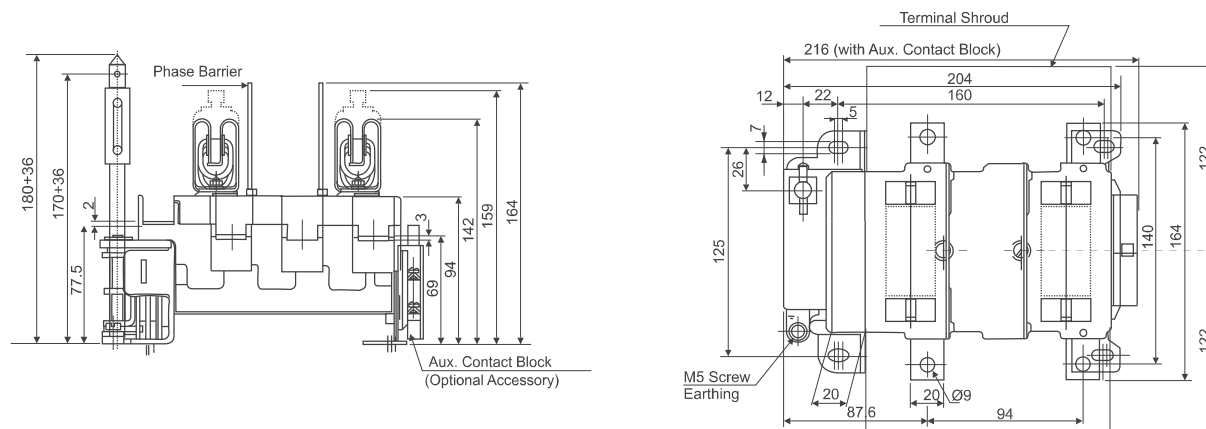

Note : All dimensions are in mm.

Overall Dimensions FN 160

› SDF - FN 160 TPN

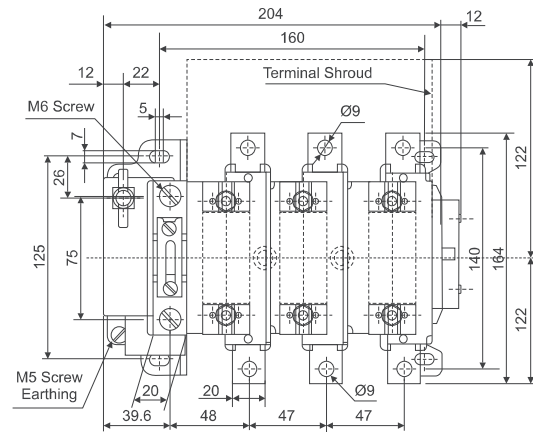
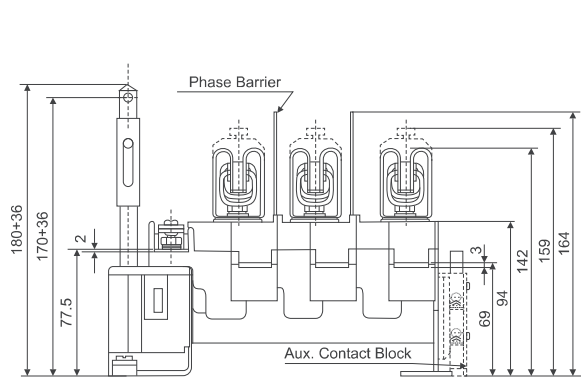

› SDF - FN 160 4P

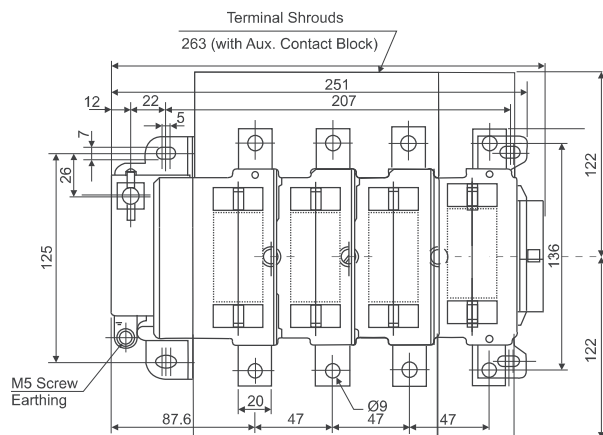
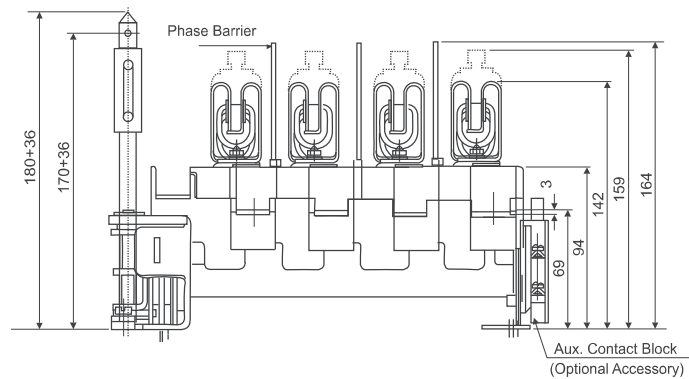

Note : All dimensions are in mm.

Overall Dimensions FN 100 / 125 / 160

Switch-Disconnecter-Fuse (suitable for Bolted type fuses)

› SDF - FN 100/125/160 TPN

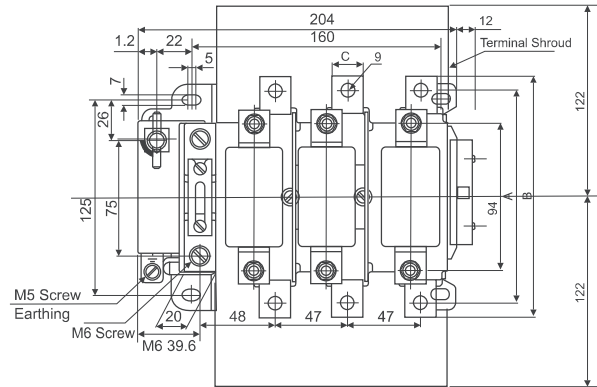
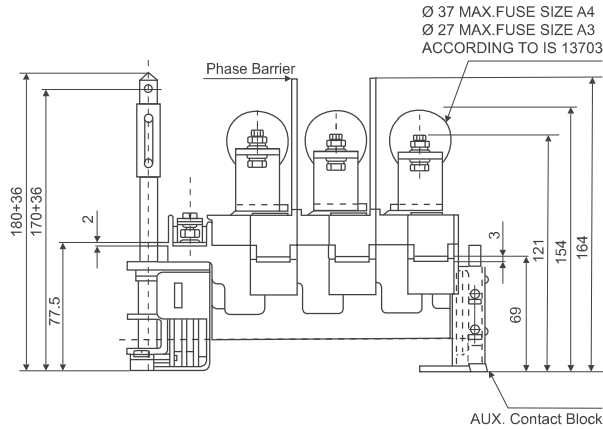

| Dimensions | A | B | C |
|--------------|-----|-----|----|
| FN 100 / 125 | 136 | 154 | 20 |
| FN 160 | 140 | 164 | 25 |

› Drilling details on Door FN 100/125/160

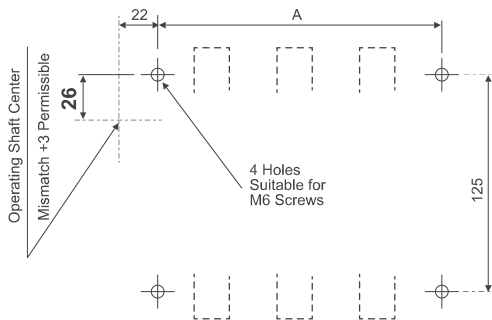

| Dimensions | For 2P & 3P Switches | For 4P Switches |
|------------|----------------------|-----------------|
| A | 160 | 207 |

› Assembly of Handle Coupling on Door FN 100 / 125 / 160

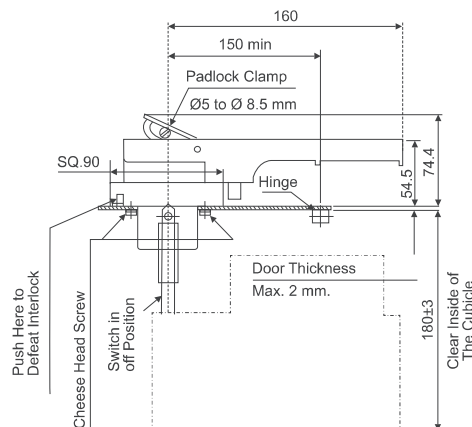

Note : All dimensions are in mm.

Overall Dimensions FN 100 / 125 / 160

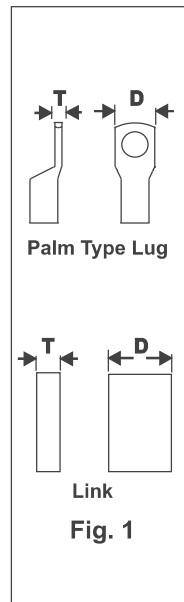

| Conductor sizes as per standard | | |
|---------------------------------|--------------------|---------------------|
| | Cu | Al |
| 100 A | 35 mm ² | 50 mm ² |
| 125 A | 50 mm ² | 70 mm ² |
| 160 A | 70 mm ² | 120 mm ² |

| Termination | FN 100/125/160 | |
|--------------------------|----------------|-----------|
| | D (Max) * | T (Max) * |
| Cable with palm type lug | 23 | 4 X 2 |
| Link | 23 | 4 X 2 |

| Rating | Terminal scew size & torque | Neutral scew size & torque |
|--------|-----------------------------|----------------------------|
| FN 100 | M8 - 9.6 Nm | M6 - 4.5 Nm |
| FN 125 | | |
| FN 160 | | |

Note : All dimensions are in mm.

Overall Dimensions FN 200

Switch-Disconnecter-Fuse (suitable for DIN type fuses)

› SDF - FN200 2P

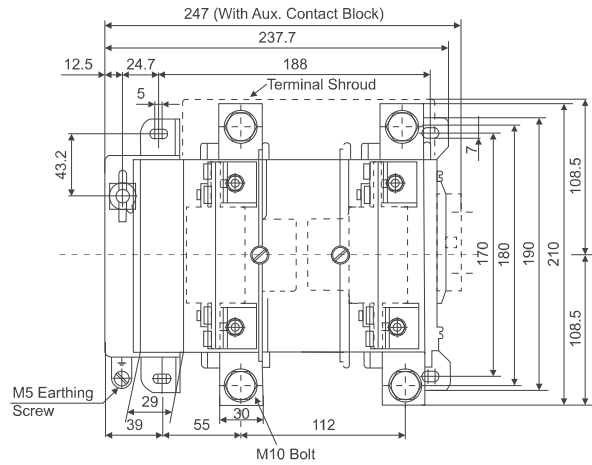
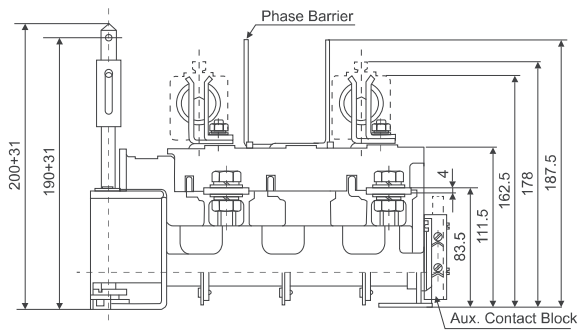

› SDF - FN200 TPN

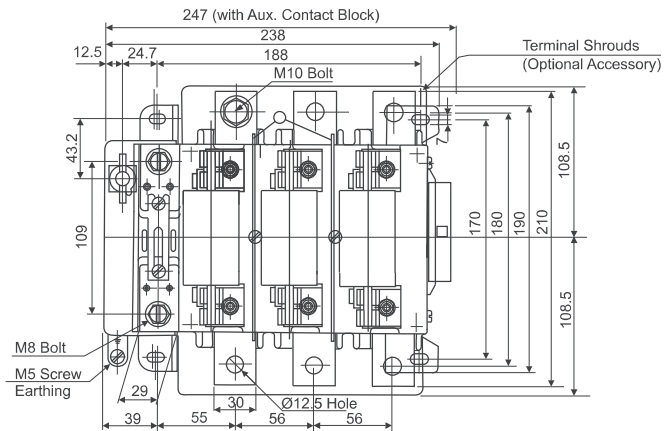
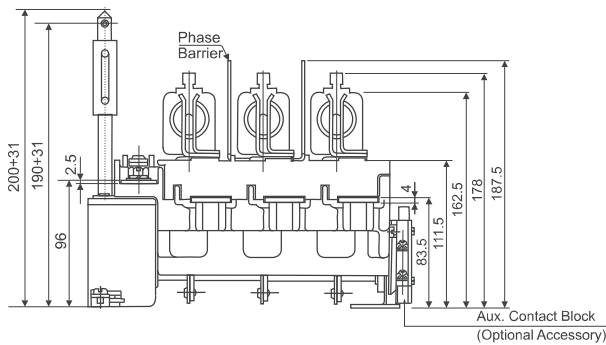

Note : All dimensions are in mm.

Overall Dimensions FN 200 / 250

› SDF - FN 200 4P

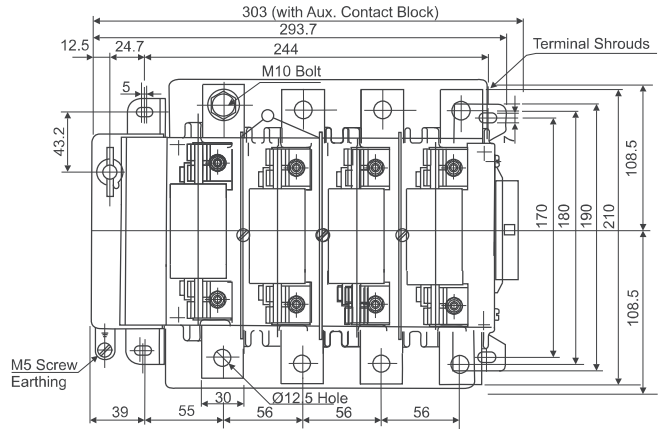
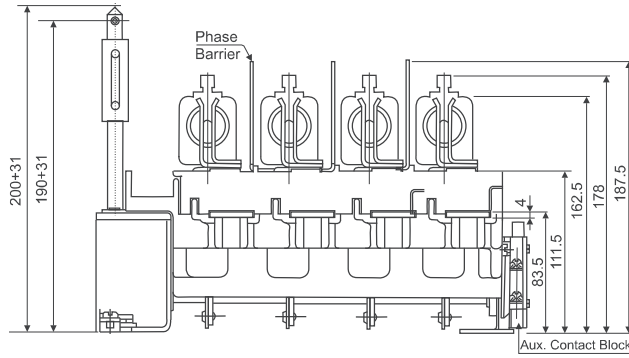

Switch-Disconnecter-Fuse (suitable for BOLTED type fuses)

› SDF - FN 200 / 250 TPN

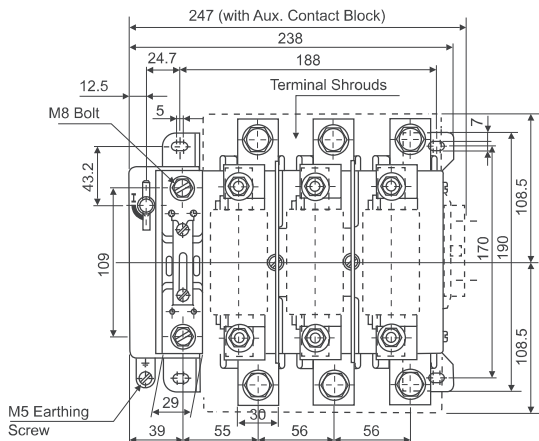
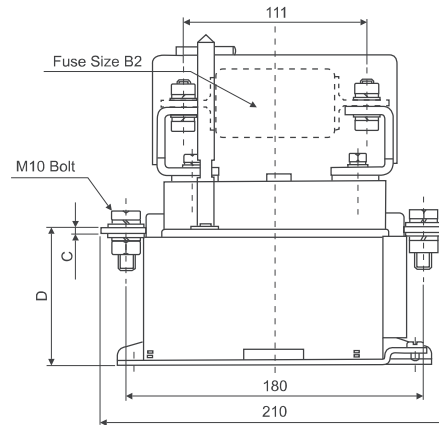
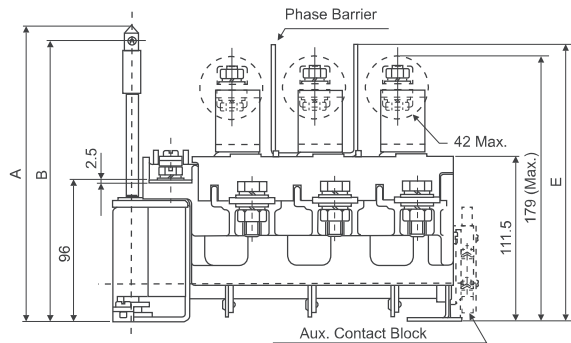

| Dimensions | A | B | C | D | E | Fuse |
|------------|--------|--------|---|------|-------|------|
| FN 200 | 200+31 | 190+31 | 4 | 83.5 | 187.5 | 200A |
| FN 250 | 216+31 | 206+31 | 5 | 84.5 | 204 | 250A |

Note : All dimensions are in mm.

Overall Dimensions FN 200 / 250 / 315 / 400

› Assembly of handle coupling on door

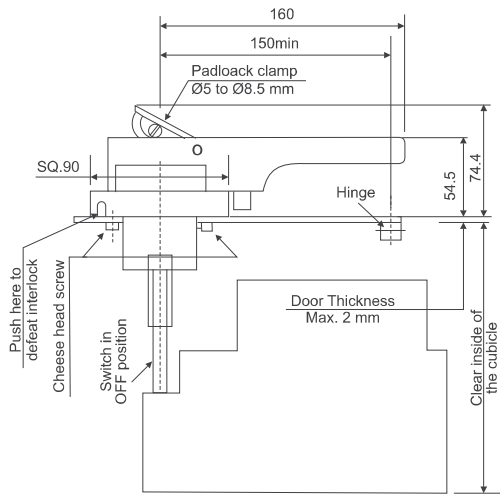

| Dimensions | FN 200 | FN 250 |
|------------|--------|--------|
| A | 200 | 216 |

› Drilling details on base plate for mounting switch seen from front of the door

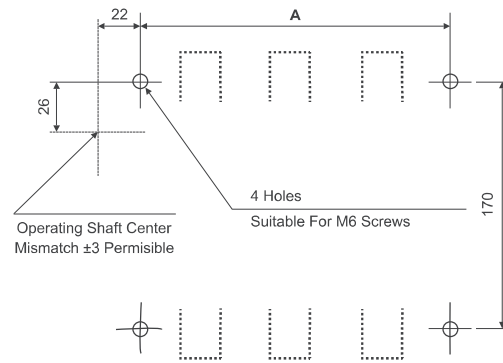

Switch-Disconnecter-Fuse (suitable for DIN type fuses)

› SDF - 315 / 400 2P

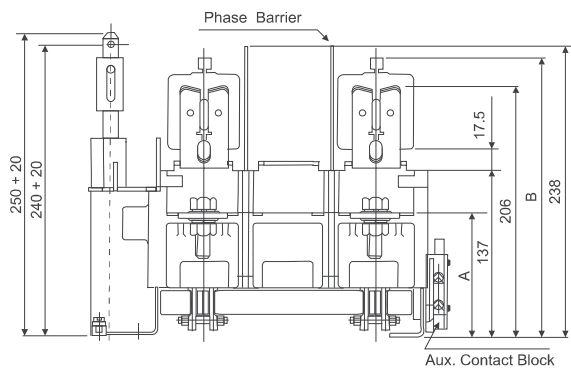

| Dimensions | A | B | C |
|------------|-----|-----|-----|
| FN 315 | 103 | 220 | M10 |
| FN 400 | 102 | 228 | M12 |

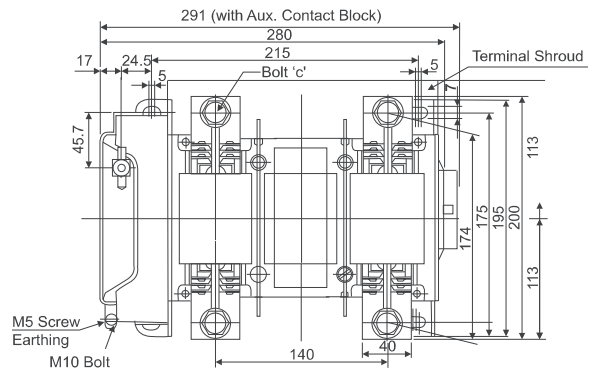

Note : All dimensions are in mm.

Overall Dimensions FN 315 / 400

› SDF - 315 / 400 TPN

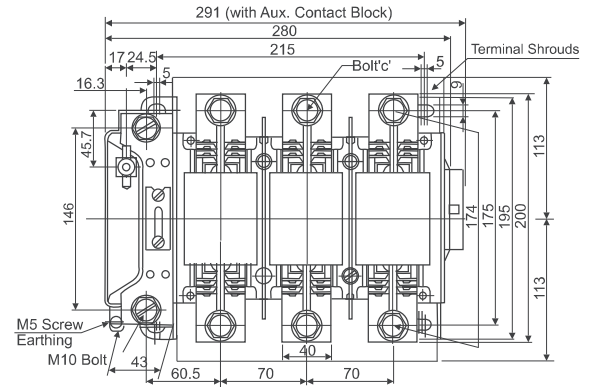
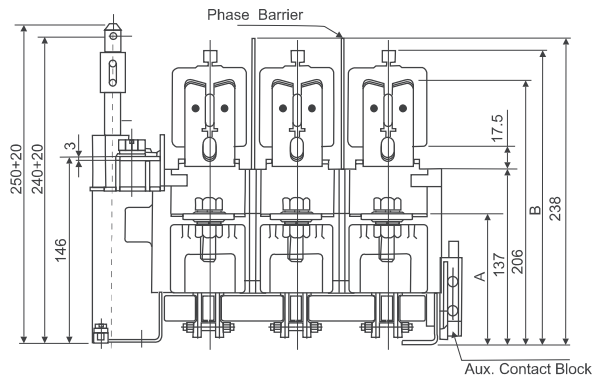

| Dimensions | A | B | C |
|------------|-----|-----|-----|
| FN 315 | 103 | 220 | M10 |
| FN 400 | 102 | 228 | M12 |

› SDF - 315 / 400 4P

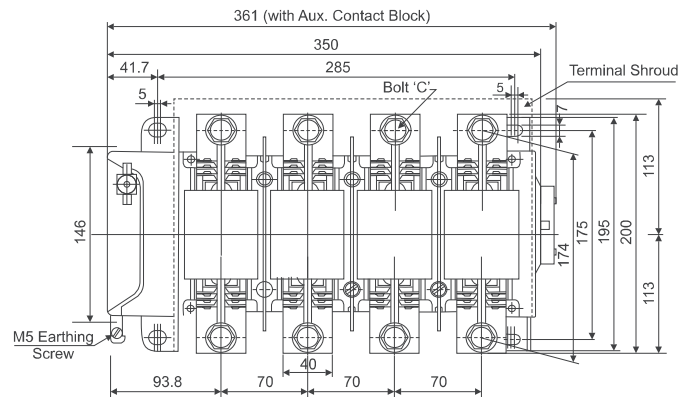
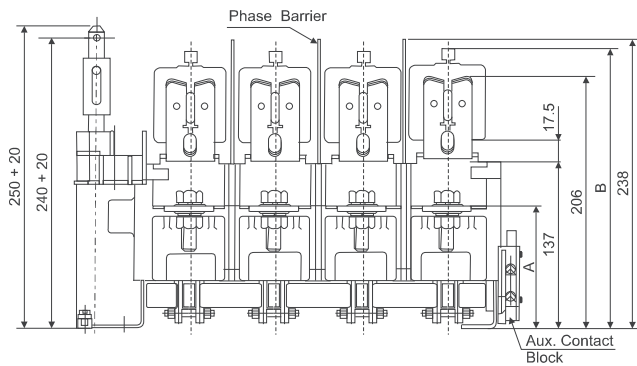

| Type | A | B | C |
|--------|-----|-----|-----|
| FN 315 | 103 | 220 | M10 |
| FN 400 | 102 | 228 | M12 |

Note : All dimensions are in mm.

Overall Dimensions FN 315 / 400

Switch-Disconnecter-Fuse (suitable for BOLTED type fuses)

› SDF - FN 315 / 400 TPN

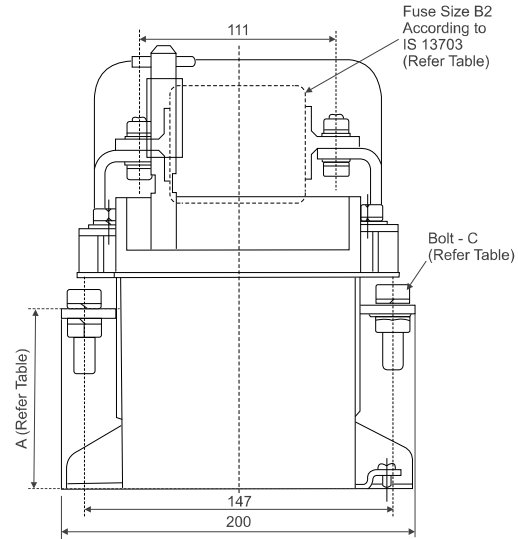
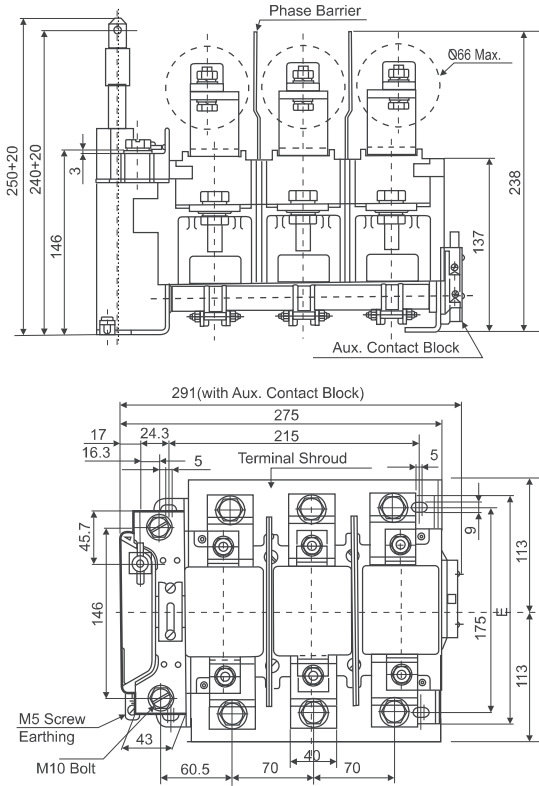

| Rating | E |
|-------------|-----|
| FN 315/250H | 195 |
| FN 400 | 235 |

› Assembly of handle coupling on door

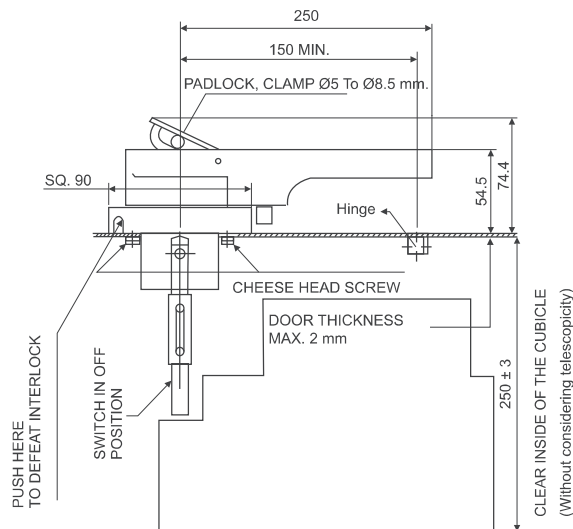

› Drilling details on door for mounting handle coupling

Seen from front of the door

DRILLING DETAILS ON BASE PLATE FOR MOUNTING SWITCH SEEN FROM FRONT OF THE DOOR

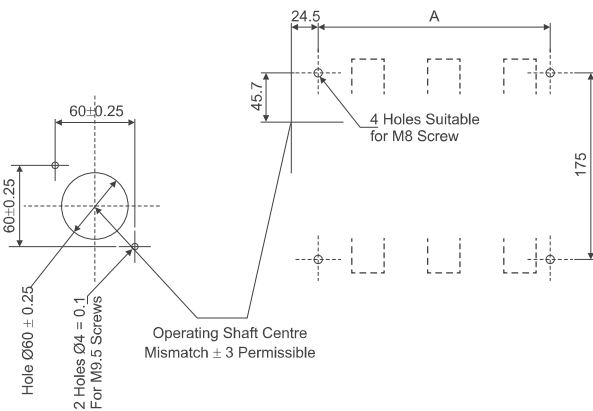

| Dimensions | For 2P & 3P Switches | For 4P Switches |
|------------|----------------------|-----------------|
| A | 215 | 285 |

Note : All dimensions are in mm.

Overall Dimensions FN 630 / 800

Switch-Disconnecter-Fuse
(suitable for DIN type fuses)

› SDF - FN 630 2P

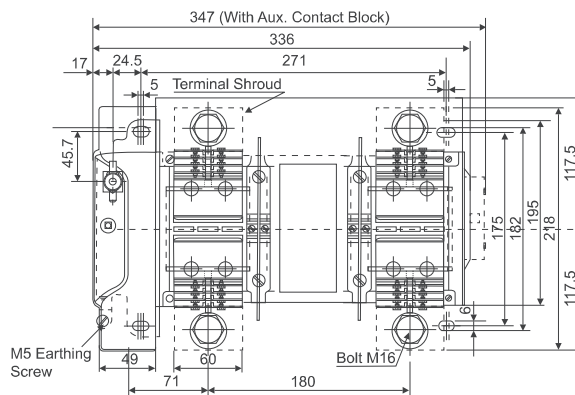
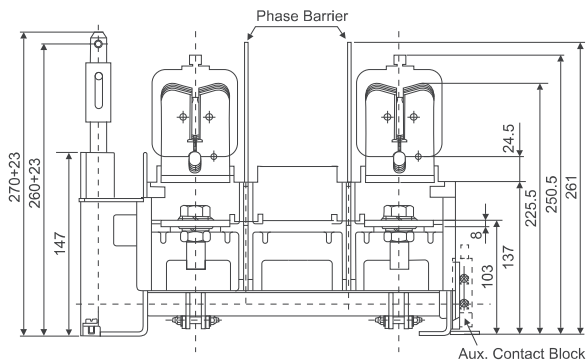

› SDF - FN 630 TPN

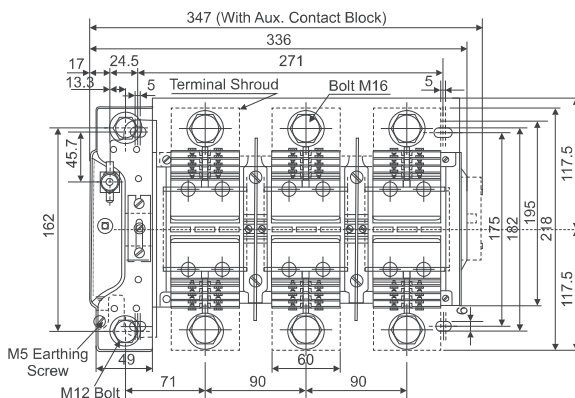
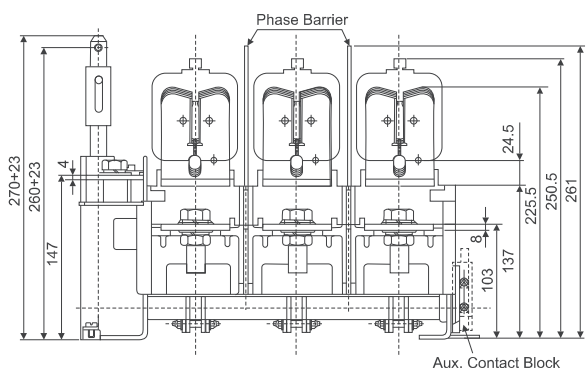

Note : All dimensions are in mm.

Overall Dimensions FN 630 / 800

› SDF - FN 630 4P

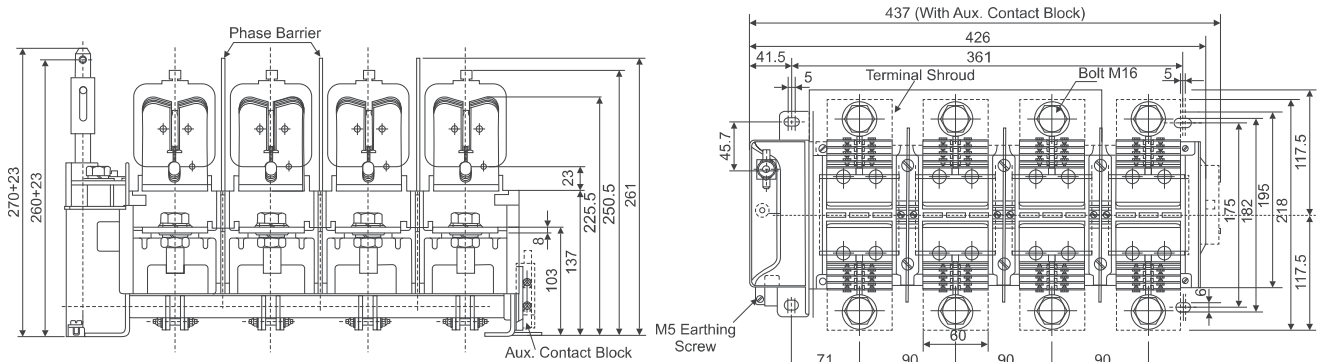

Switch-Disconnecter-Fuse (suitable for BOLTED type fuses)

› SDF - FN 630 TPN

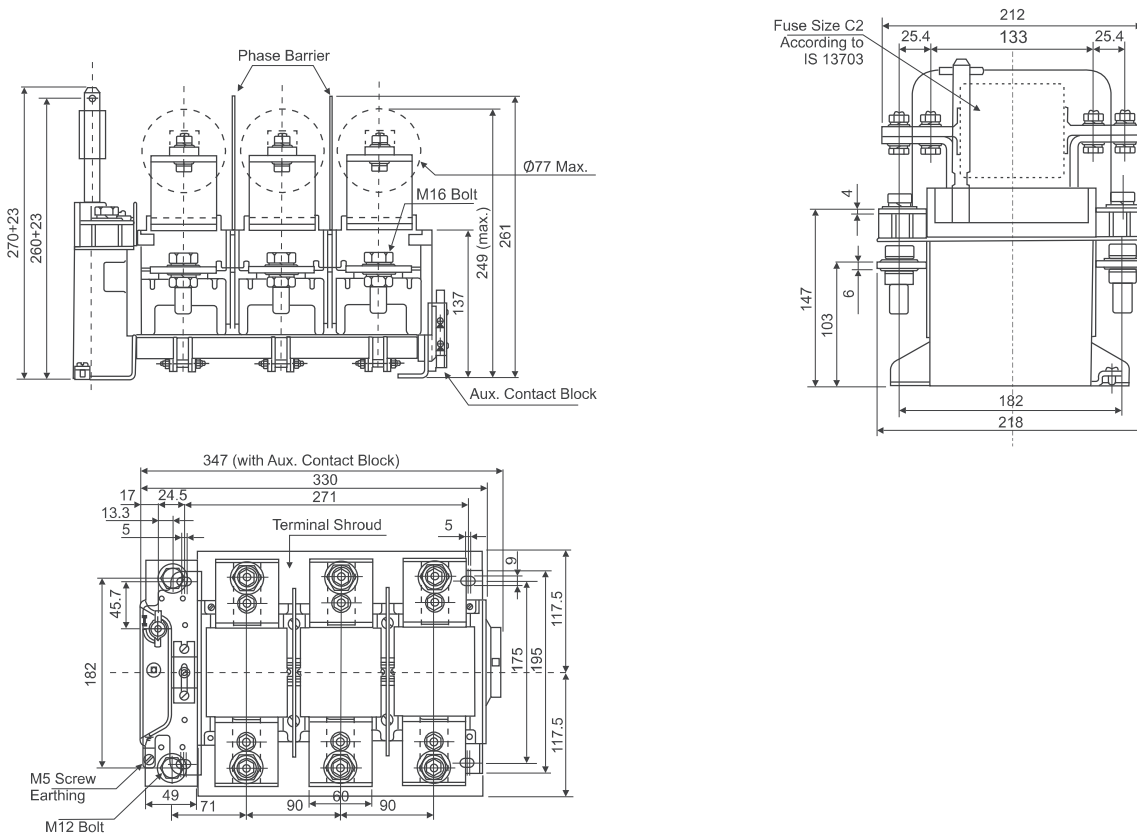

Note : All dimensions are in mm.

Overall Dimensions FN 32 / 63

Assembly of Handle Coupling on Door

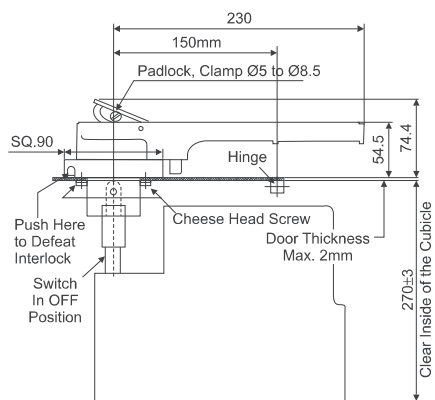

Drilling Details on Base Plate for Mounting Switch Seen From Front of the Door

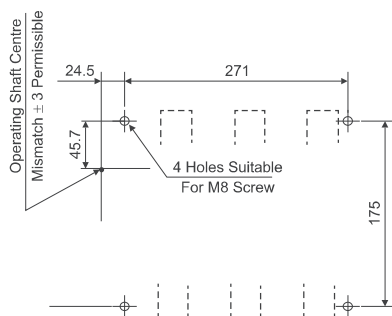

| Switch Type | A |
|-------------|-----|
| 2P & 3P | 271 |
| 4P | 361 |

Note : All dimensions are in mm.

FN in Sheet Steel Enclosure

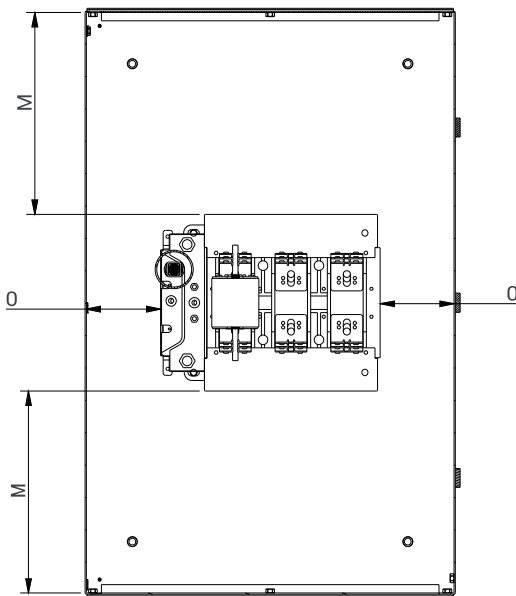
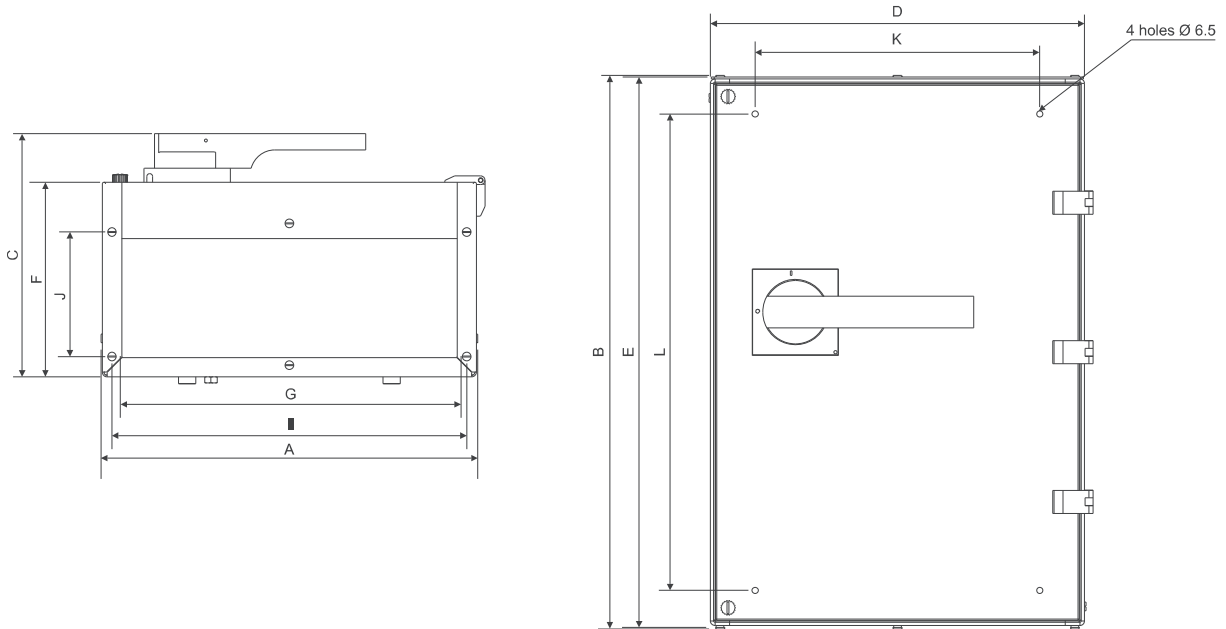

Section A-A

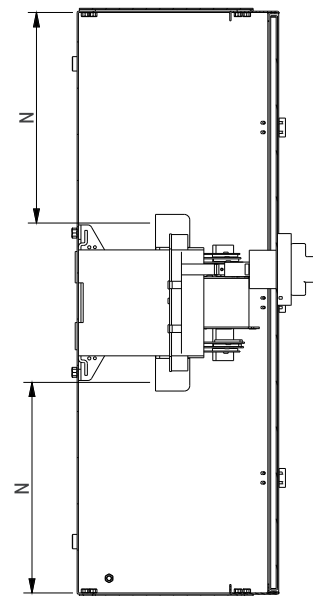

Section B-B

| Type | Extreme overall dimension | | | Basic enclosure dimension | | | Cutout for Cables | | GI and Plate mounting dimension | | Enclosure mounting dimension | | M | N | O |
|--------------------|---------------------------|-----|-----|---------------------------|-----|-----|-------------------|-----|---------------------------------|-----|------------------------------|-----|-----|-----|----|
| | A | B | C | D | E | F | G | H | I | J | K | L | | | |
| FN 32 / 63 | 277 | 325 | 196 | 262 | 310 | 153 | 222 | 108 | 242 | 113 | 160 | 230 | 75 | 105 | 73 |
| FN 100 / 125 / 160 | 330 | 448 | 245 | 315 | 433 | 183 | 275 | 108 | 295 | 113 | 213 | 350 | 92 | 132 | 54 |
| FN 200 / 250 | 405 | 585 | 265 | 390 | 570 | 203 | 350 | 130 | 370 | 130 | 213 | 350 | 175 | 171 | 46 |
| FN 315 / 400 | 480 | 747 | 315 | 465 | 732 | 253 | 425 | 171 | 445 | 180 | 346 | 600 | 250 | 264 | 90 |
| FN 630 / 800 | 480 | 747 | 337 | 465 | 732 | 273 | 425 | 171 | 445 | 180 | 346 | 600 | 246 | 255 | 63 |

Note : All dimensions are in mm.

Earthing Link Assembly

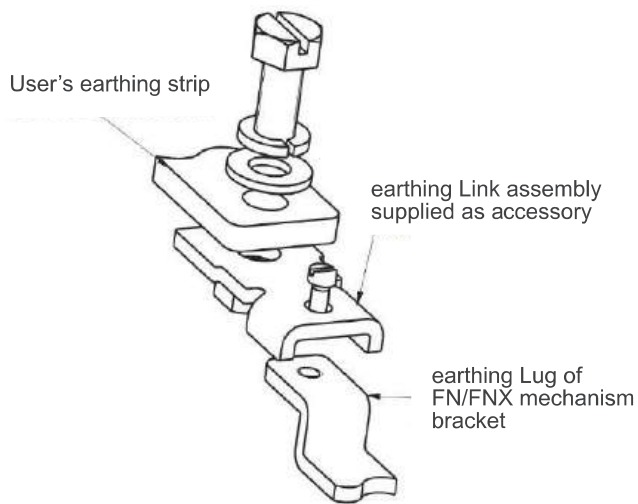

The earthing link is to be connected to the earth terminal.

Now, an increased area is available for terminating earth busbar upto 25 mm width.

Note: The earthing link is available as an accessory.
All the necessary hardware is provided with the product

| Applicable for ratings, 125A to 1000A | | |
|---------------------------------------|-----------|-----------------------|
| CAT no. | Order Qty | No. of earthing links |
| Ck903960000 | 1 | 10 |

Assembly of Castell Lock with Telescopic Shaft

Arrangement of Castell Lock Inside the Panel

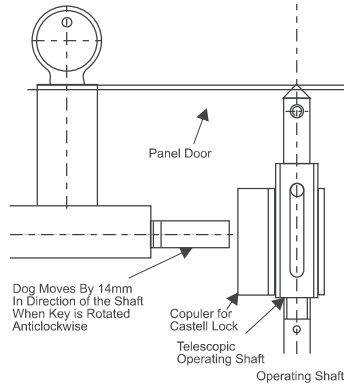

Castell Lock Positions with Telescopic Shaft

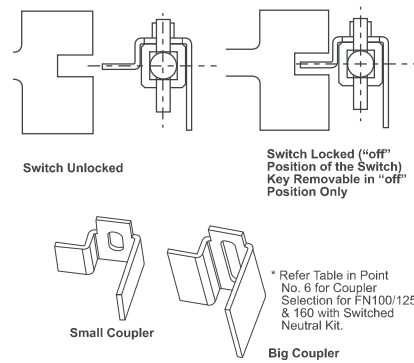

Mounting of Castell Lock Coupler

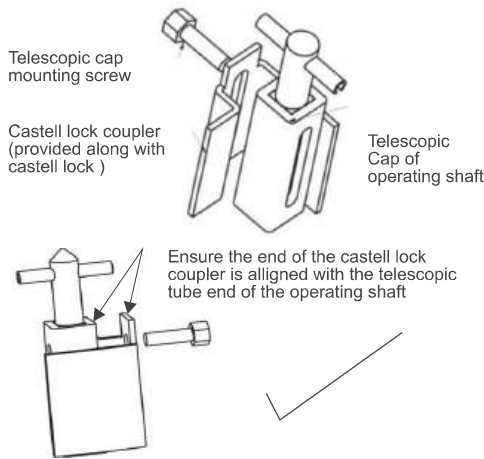

Drilling Details on Door for Castell Lock

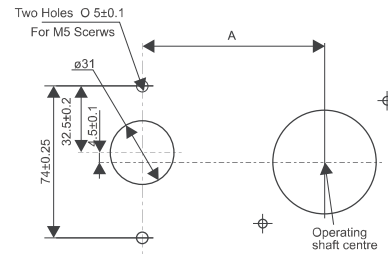

| Suitable for | Cat no. | Dim. A |
|---------------------------|---------|-----------|
| 160/200/250 FN 100/125 | SK00333 | 88±0.25 |
| | SK00334 | |
| | SK00335 | |
| | SK00336 | |
| FN 315/400/ 630/800 | SK00345 | 95.5±0.25 |
| | SK00346 | |
| | SK00347 | |
| | SK00348 | |

Wrong method of assembly (as seen from front side in mounted condition)

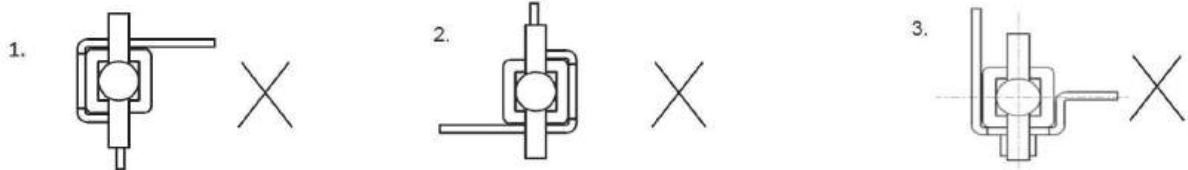

Coupler selection guide for FN 100/125/160**

| Product | Castell Lock No. | Switched Neutral Kit used | Shaft telescopicity used | Castell lock Coupler to be used |
|-------------------|------------------|---------------------------|--------------------------|---------------------------------|
| FN 100/125/160 | SK00333 | Yes | No | Small |
| | | | Yes | Big |
| | | | No | Small |
| | | | Yes | Big |
| | | | No | Small |
| | | | Yes | Big |
| | SK00334 | NO | No | Big |
| | | | Yes | |
| | | | No | |
| | | | Yes | |
| | | | No | |
| | | | Yes | |
| SK00335 | NO | No | Big | |
| | | Yes | | |
| | | No | | |
| | | Yes | | |
| SK00336 | NO | No | Big | |
| | | Yes | | |
| | | No | | |
| | | Yes | | |

** Small coupler not required for FN200/250

Note : All dimensions are in mm.

Contents

| | |
|-------------------------|----|
| CZ Switch Disconnectors | 48 |
| Product Range | 49 |
| Overall Dimensions | 55 |

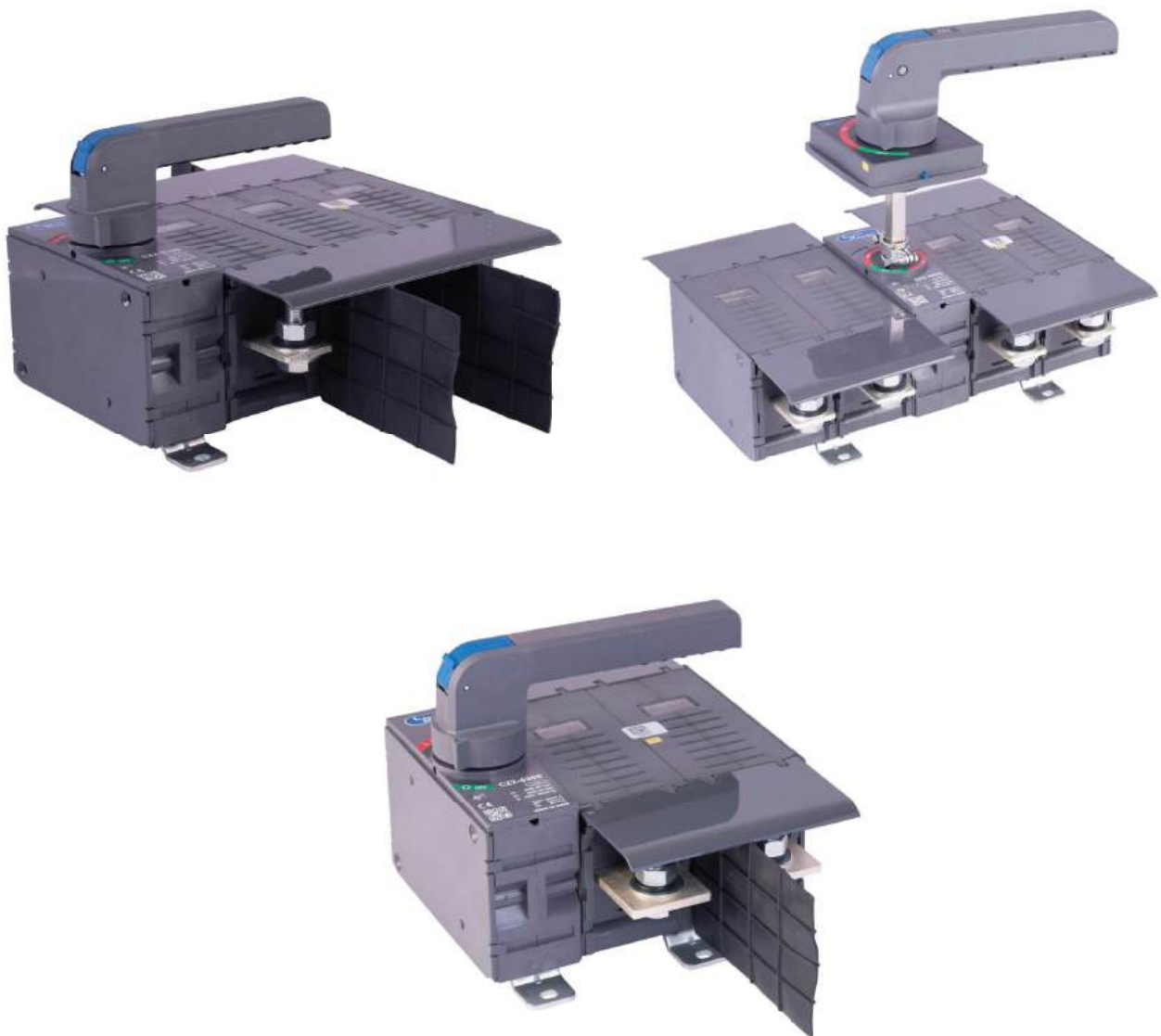

CZ Switch Disconnectors

E&A now offers wide range of Switch-Disconnectors suitable for multitude of applications like power distribution, isolation in solar power plants, local ON/OFF control for machines & motor, to name a few. Available in both open and ready to use SS enclosure versions, the CZ Switch Disconnectors are easy to install, operate and inspect. Armored with safety features like terminal shrouds, phase barriers & door interlock, the CZ Switch Disconnectors are designed to battle against accidental faults and inadvertent operations. Robust construction allows to withstand higher fault currents without any deterioration.

Designed For Indian Ambient Conditions

CZ Switch Disconnectors are rugged and suitable to carry rated current at high temperatures experienced in Indian Sub-Continent. Also, the terminals are designed to accommodate Aluminum cables/bus bars.

Safety Guaranteed

There is no benefit of the doubt allowed when it comes to safety. Terminal shrouds protect against accidental human contact with the live terminals, phase barriers stand in line of any phase to phase flashovers and high ground clearance eliminates any possibility of grounding live cables/links.

Different Operational Voltages For Different Needs

CZ family of Switch Disconnectors have dedicated range for different voltages (upto 800V AC, 1000V DC, 1500V DC). While power distribution normally requires 415V ac rated SDs, other applications like metal furnaces require 690V ac SDs. Also, 800 Vac and 1500 Vdc SDs are common requirement in Solar applications.

Diverse Needs, Varied Options

Both direct and extended handle versions are available to meet diverse application needs. The extended or panel mounted handle is IP54 rated for extreme external environment. Also, the length of the extended shaft can be adjusted to align with different panel sizes.

Contact System & Mechanism

CZ SDs have modular construction with separate cassettes for mechanism and contact system. Contact system cassette (pole assembly) consists of rotor assembly housing moving contacts, terminals and arc-chutes. The contact system is double break knife type. Mechanism is quick make-quick break and multi-cams type for smooth and efficient torque transmission. Moreover, the contacts are visible through transparent window section to know actual status of contact system

For A Sustainable Future

All the materials used for components, welding and plating on metallic components are RoHS compliant. Material used for packaging is recyclable.

Accessories

a) Auxiliary Contacts

Upto 2nos. 1NO + 1NC can be fitted for ON/OFF status indication. The auxiliary contacts module is front mounted, plug-in type and can be fitted at the site. Auxiliary contacts actuation is from the main mechanism shaft. Addition of these contacts does not alter over-all dimensions of the switch.

b) Castell Key Lock

The CZ SDs can be interlocked with the help of Castell locks.

Product Range

| Product Range and Versions | Voltage | No. of poles | Handle Type | % saving in electricity consumed |
|----------------------------|---------|--------------|-------------|----------------------------------|
| CZ Switch Disconnecter | 800 Vac | 2P | Extended | Front Operated, Side |
| | 800 Vac | 3P | Direct | Front Operated, Side |
| | 800 Vac | 3P | Extended | Front Operated, Side |
| | 800 Vac | 4P | Direct | Front Operated, Center |
| | 800 Vac | 4P | Extended | Front Operated, Center |

Universal Mounting

| Sr. No. | Handle (OFF) Position | Operating Quadrant (hand) | Switch Orientation | Door Cut-out | Shaft Position |
|---------|-----------------------|---------------------------|--------------------|--------------|----------------|
| 1 | | | | | |
| 2 | | | | | |
| 3 | | | | | |
| 4 | | | | | |

Detailed View

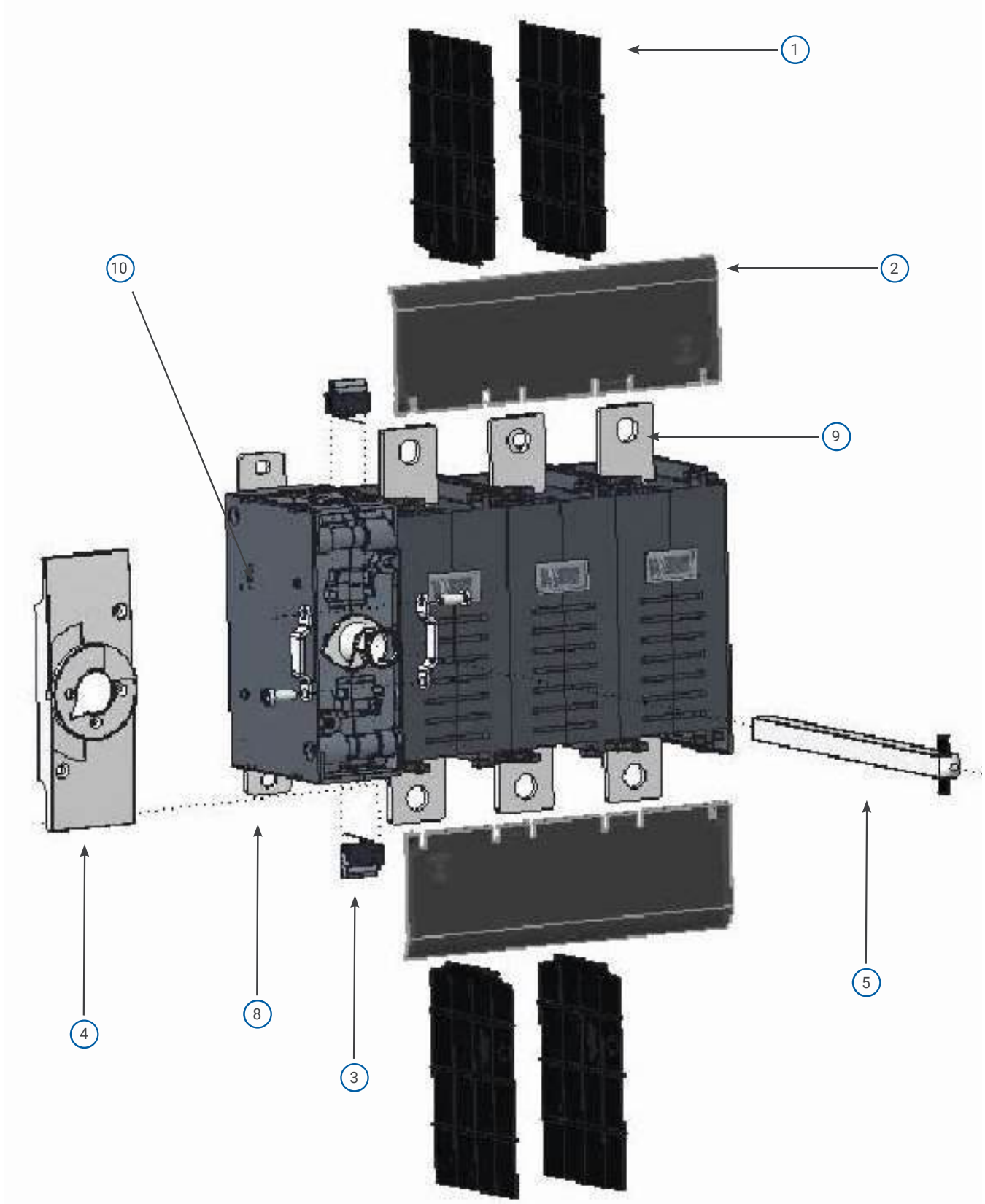

11

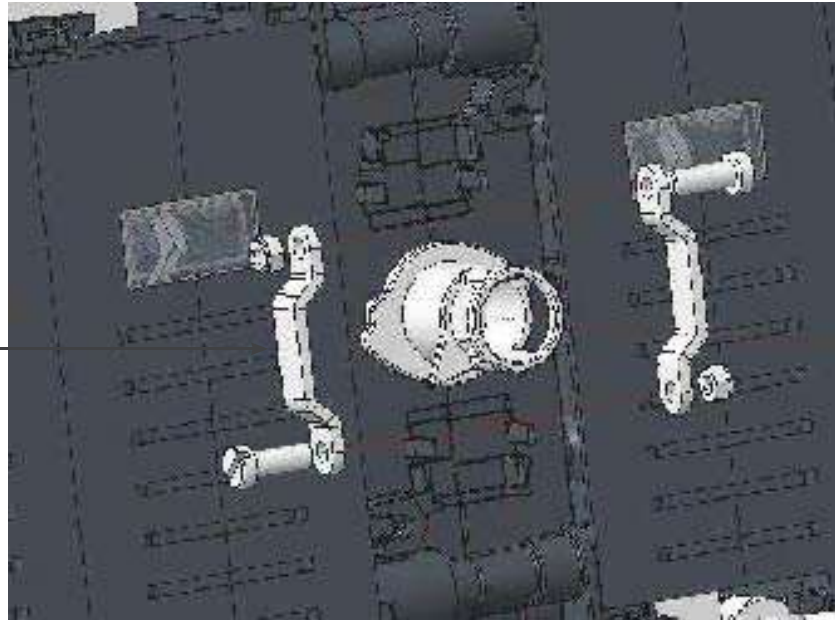

6

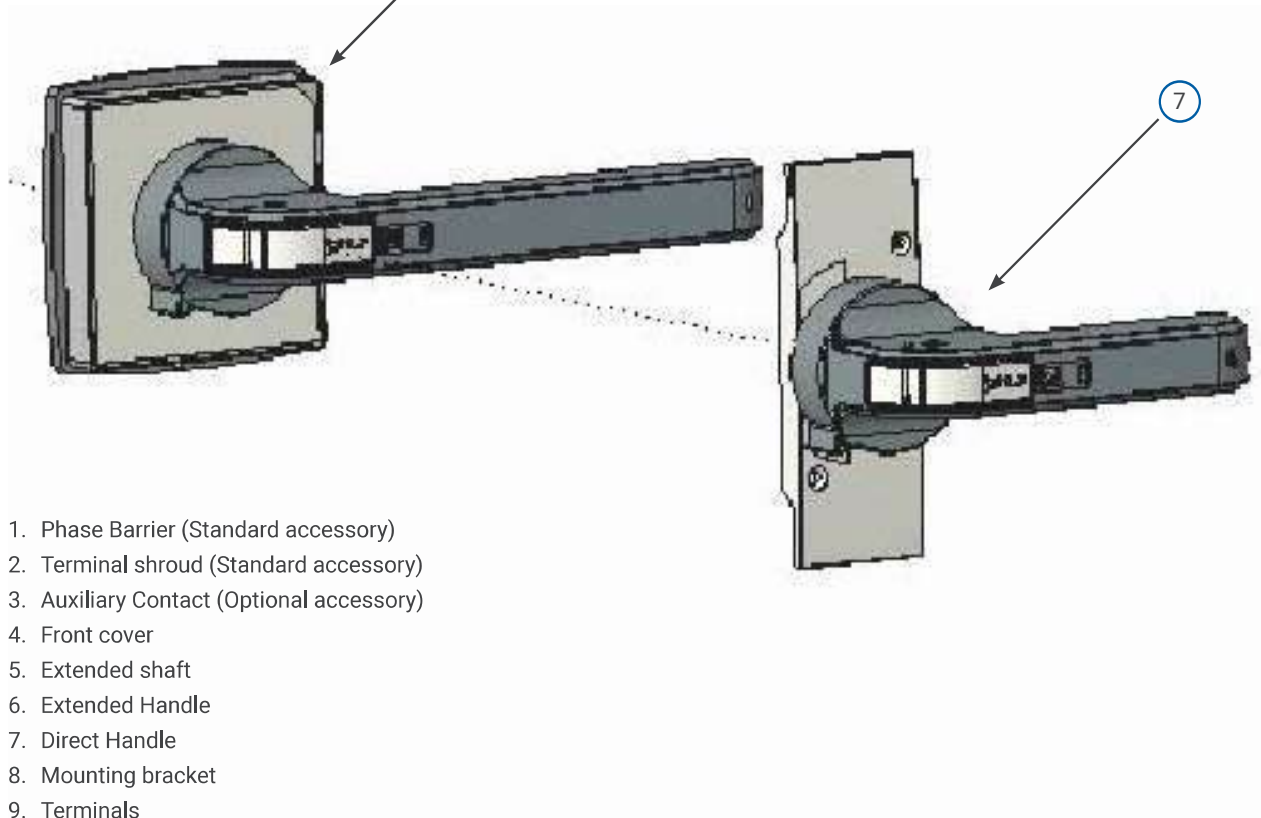

7

- 1. Phase Barrier (Standard accessory)
- 2. Terminal shroud (Standard accessory)
- 3. Auxiliary Contact (Optional accessory)
- 4. Front cover
- 5. Extended shaft
- 6. Extended Handle
- 7. Direct Handle
- 8. Mounting bracket
- 9. Terminals
- 10. Shaft locking arrangement
- 11. Detailed view of shaft locking arrangement

Technical Specification for AC Switch Disconnectors

| | | | 125A | 160A |
|-----------------------------------------------------------------|-------------------|-----------------|-------------|-----------|
| Model | | | CZ-1 | CZ-1 |
| Compliance to Standards | | | | |
| No. of Poles | | | 2,3,4 | 2,3,4 |
| Conventional enclosed thermal current (I _{the}) | 40°C | A | 125 | 160 |
| | 50°C | A | 125 | 160 |
| Pollution Degree | | | 3 | 3 |
| Rated Operational Voltage (U _e , Max) | V | | 800 | 800 |
| Rated Impulse withstand voltage (U _{imp}) | kV | | 12 | 12 |
| Rated Insulation voltage (U _i) | V | | 1250 | 1250 |
| Rated Frequency | Hz | | | |
| Rated Operational Current (I _e) | AC-23A at 690Vac | A | 125 | 160 |
| Rated Operational Current/Poles in Series; DC 21B | 220Vdc | A | 125/1 | 160/1 |
| | 440Vdc | A | 125/2 | 160/2 |
| Rated Short Time Withstand Current (I _{cw} , rms) | 1 Sec | kA | 8 | 8 |
| | 0.15 sec | kA | 15 | 15 |
| | 0.25 Sec | kA | 15 | 15 |
| Rated Short Circuit Making Capacity (I _{cm} , Peak) | kA | | 30 | 30 |
| Rated Conditional Short-Circuit Current (I _q , Peak) | kA | | 100 | 100 |
| Rated Breaking Capacity | AC-23A at 690 Vac | kA | 1.0 | 1.3 |
| Rated Operational Power, AC-23A | At 415V | kW | 75 | 90 |
| | At 690V | kW | 110 | 160 |
| Power Loss/Pole | W | | 1.8 | 2.9 |
| Operational Performance capability | Electrical | Nos. | 2000 | 2000 |
| | Mechanical | Nos. | 20000 | 20000 |
| Operating Torque | N-m | | 9 | 9 |
| Maximum Termination Capacity | Lug Size | mm ² | 2 X 185 | 2 X 85 |
| | Link Size | mm ² | 2 X 35 X 10 | 2 X35 X10 |
| Terminal Bolt size | | | M10 | M10 |
| Terminal Tightening Torque | N-m | | 20 | 20 |
| Weight | 4P | kg | 2.4 | 2.4 |

| 200A | 250A | 315A | 315A | 400A | 630A |
|-----------------------------------------|-------------|-------------|-------------|-------------|-------------|
| CZ-1 | CZ-1 | CZ-1 | CZ-2 | CZ-2 | CZ-2 |
| IEC 60947-3, IS/IEC 60947-3, EN 60947-3 | | | | | |
| 2,3,4 | 2,3,4 | 2,3,4 | 2,3,4 | 2,3,4 | 2,3,4 |
| 200 | 250 | 315 | 315 | 400 | 630 |
| 200 | 250 | 315 | 315 | 400 | 630 |
| 3 | 3 | 3 | 3 | 3 | 3 |
| 800 | 800 | 800 | 800 | 800 | 800 |
| 12 | 12 | 12 | 12 | 12 | 12 |
| 1250 | 1250 | 1250 | 1250 | 1250 | 1250 |
| 50/60 | | | | | |
| 200 | 250 | 315 | 315 | 400 | 630 |
| 200/1 | 250/1 | 315/1 | 315/1 | 400/1 | 630/1 |
| 200/2 | 250/2 | 315/2 | 315/2 | 315/2 | 630/2 |
| 8 | 8 | 10 | 16 | 16 | 20 |
| 15 | 15 | 15 | 31 | 31 | 38 |
| 15 | 15 | 15 | 24 | 24 | 36 |
| 30 | 30 | 30 | 45 | 45 | 45 |
| 100 | 100 | 100 | 100 | 100 | 100 |
| 1.6 | 2.0 | 2.5 | 2.5 | 3.2 | 5.0 |
| 110 | 132 | 160 | 160 | 200 | 355 |
| 180 | 200 | 250 | 250 | 355 | 600 |
| 4.6 | 7.1 | 11.3 | 7.5 | 12.2 | 23.8 |
| 2000 | 2000 | 2000 | 2000 | 2000 | 2000 |
| 20000 | 20000 | 20000 | 20000 | 20000 | 20000 |
| 9 | 9 | 9 | 18 | 18 | 20 |
| 2 X 185 | 2 X 185 | 2 X 240 | 2 X 300 | 2 X 300 | 2 X 300 |
| 2 X 35 X 10 | 2 X 35 X 10 | 2 X 35 X 10 | 2 X 50 X 12 | 2 X 50 X 12 | 2 X 50 X 12 |
| M10 | M10 | M12 | M12 | M12 | M12 |
| 20 | 20 | 20 | 27 | 27 | 27 |
| 2.4 | 2.4 | 2.4 | 4.6 | 4.6 | 5.1 |

Ordering Information

| Version | Frame Size | Current Rating(A) | Voltage | No. of poles | Handle type | Mechanism Position | CAT no. |
|-------------------------------------------|------------|-------------------|---------|--------------|-------------|--------------------|--------------|
| CZ SD Open Execution SD CZ SDSS enclosure | 1 | 125A | 800Vac | 4P | P | Front, Center | CK90769 0000 |
| | 1 | 160A | 800Vac | 4P | P | Front, Center | CK90770 0000 |
| | 1 | 200A | 800Vac | 4P | P | Front, Center | CK90771 0000 |
| | 1 | 250A | 800Vac | 4P | P | Front, Center | CK90772 0000 |
| | 1 | 315A | 800Vac | 4P | P | Front, Center | CK90773 0000 |
| | 2 | 315A | 800Vac | 4P | P | Front, Center | CK90857 0000 |
| | 2 | 400A | 800Vac | 4P | P | Front, Center | CK90858 0000 |
| | 2 | 630A | 800Vac | 4P | P | Front, Center | CK90859 0000 |
| CZ SD SS enclosure | 1 | 125A | 800Vac | 4P | P | Front, Center | CK908190000 |
| | 1 | 160A | 800Vac | 4P | P | Front, Center | CK908200000 |
| | 1 | 200A | 800Vac | 4P | P | Front, Center | CK908210000 |
| | 1 | 250A | 800Vac | 4P | P | Front, Center | CK908220000 |
| | 1 | 315A | 800Vac | 4P | P | Front, Center | CK908230000 |
| | 2 | 315A | 800Vac | 4P | P | Front, Center | CK908780000 |
| | 2 | 400A | 800Vac | 4P | P | Front, Center | CK908790000 |
| | 2 | 630A | 800Vac | 4P | P | Front, Center | CK908800000 |
| CZ | 1 & 2 | 125A to 630A | 800Vac | 2P | P | Front, Side | - |
| | | | 800Vac | 3P | P | Front, Side | |
| | | | 800Vac | 3P | D | Front, Side | |
| | | | 800Vac | 4P | D | Front, Side | |
| CZ Auxiliary Contact Kit (1 C/O contact) | 1 & 2 | 125A to 630A | - | - | - | - | CK908050000 |

Notes:

* Please contact our nearest branch office for further details
 Separate offerings for Solar applications (800Vac and 1000Vdc/1500Vdc) are also available.

P-Extended handle suitable for panel door mounting
D-Direct handle suitable for direct mounting on the product

Overall Dimensions

› CZ1 AC SD 125/160/200/250/315A

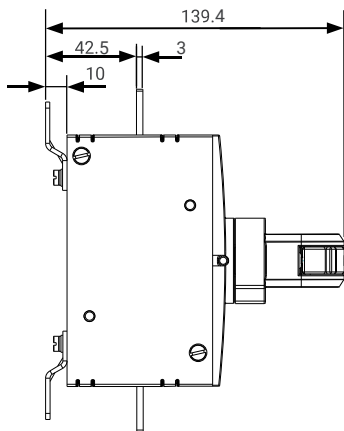
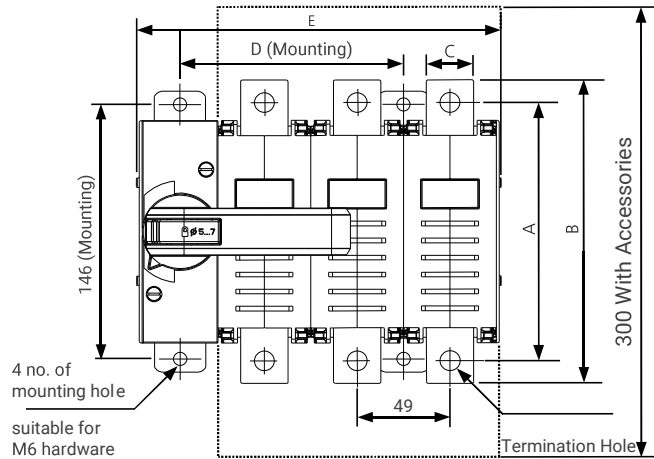

Direct Handle Version

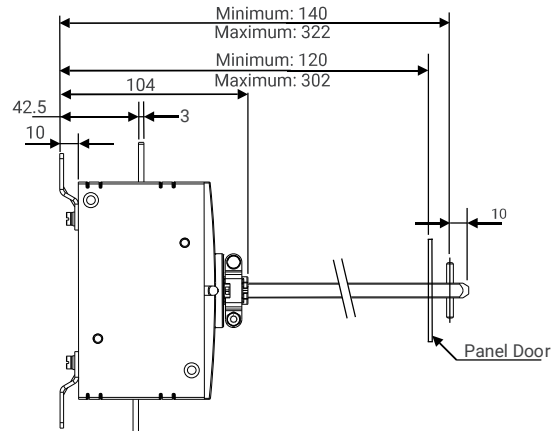

Panel Handle Version

| Rating (A) | No. of poles | A | B | C | D | E | Hardware suitable for termination |
|------------|--------------|-----|-----|----|-----|-----|-----------------------------------|
| 125-250 | 2P | 137 | 161 | 25 | 69 | 144 | M10 |
| | 3P | 137 | 161 | 25 | 118 | 193 | |
| | 4P | 137 | 161 | 25 | 138 | 242 | |
| 315 | 2P | 150 | 180 | 35 | 69 | 144 | M12 |
| | 3P | 150 | 180 | 35 | 118 | 193 | |
| | 4P | 150 | 180 | 35 | 138 | 242 | |

Overall Dimensions

› CZ1 AC SD 125/160/200/250/315A

Panel Cutout

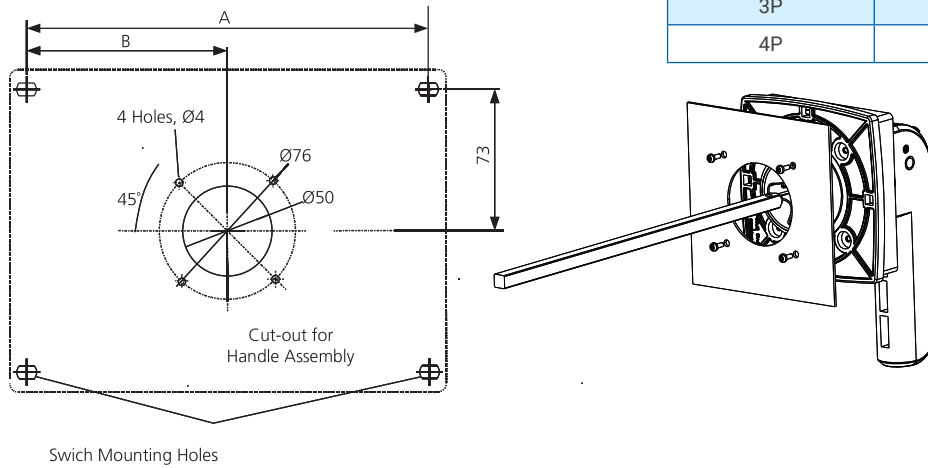

| No. of Poles | A | B |
|--------------|-----|----|
| 2P | 69 | 0 |
| 3P | 118 | 0 |
| 4P | 138 | 69 |

Enclosure size and enclosure mounting

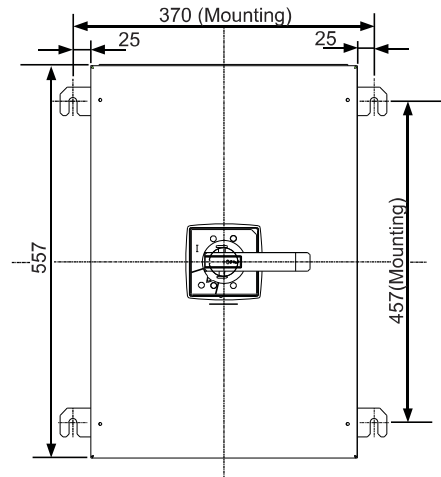
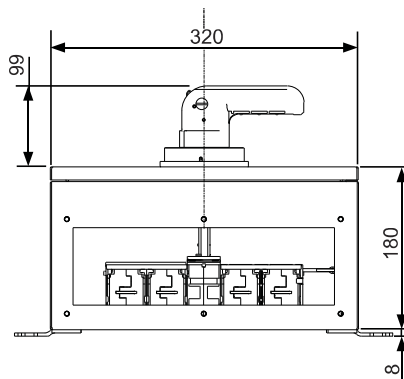

Termination Capacity

| | | 125/160/200/250A | 315 A | |
|-------------------|--------------------------------------|-----------------------------------------|---------------------------|------------------------|
| | TERMINATION CAPACITY AS PER STANDARD | Cable With Lug 1 X185mm ² | 1X240 mm ² | |
| | MAXIMUM TERMINATION CAPACITY | Cable With Lug | 2 X185mm ² | 2 X 240mm ² |
| | | Busbar* | 2 X 35mm X 10mm | 2 X 35mm X 10mm |
| TIGHTENING TORQUE | | MAX 20 N-m AT TERMINATION | MAX 20 N-m AT TERMINATION | |

Note: For Aluminum cable, Tin plated lugs are recommended.

Termination bolt head should be on bottom side as shown in figures

*: Higher length (M10 X 40 for 250A; M12 X 40 for 315A) of termination bolt required to connect 2 busbar of 10mm.

Overall Dimensions

› CZ2 AC SD 315/400/630A

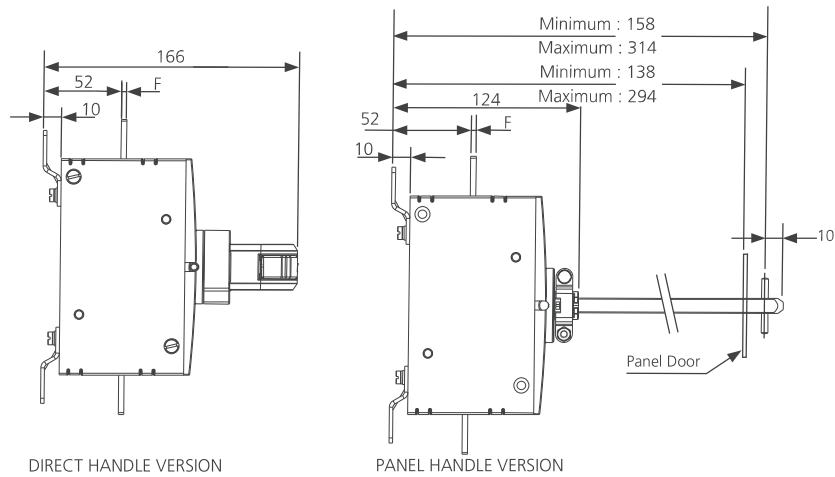
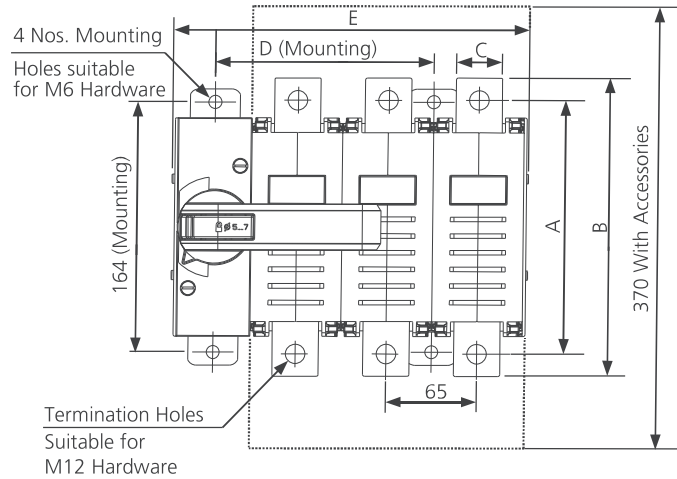

| Rating (A) | No. of Poles | A | B | C | D | E | F |
|------------|--------------|-----|-----|----|-----|-----|---|
| 315/400 | 2P | 181 | 206 | 32 | 90 | 186 | 4 |
| | 3P | 181 | 206 | 32 | 155 | 251 | 4 |
| | 4P (SIDE) | 181 | 206 | 32 | 220 | 316 | 4 |
| | 4P (CENTRE) | 181 | 206 | 32 | 180 | 316 | 4 |
| 630 | 2P | 184 | 222 | 45 | 90 | 186 | 5 |
| | 3P | 184 | 222 | 45 | 155 | 251 | 5 |
| | 4P (SIDE) | 184 | 222 | 45 | 220 | 316 | 5 |
| | 4P (CENTRE) | 184 | 222 | 45 | 180 | 316 | 5 |

Overall Dimensions

› CZ1 AC SD 125/160/200/250/315A

Panel Cutout

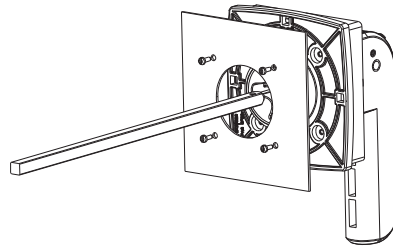
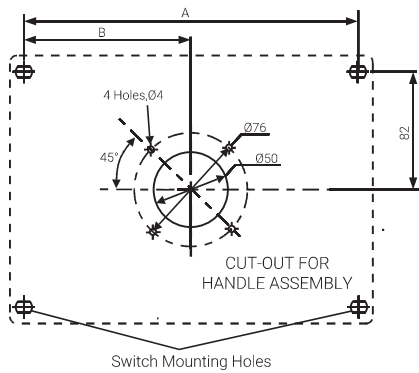

| No. of Poles | A | B |
|--------------|-----|----|
| 2P | 90 | 0 |
| 3P | 155 | 0 |
| 4P - SIDE | 220 | 0 |
| 4P - CENTER | 180 | 90 |

Enclosure size and enclosure mounting

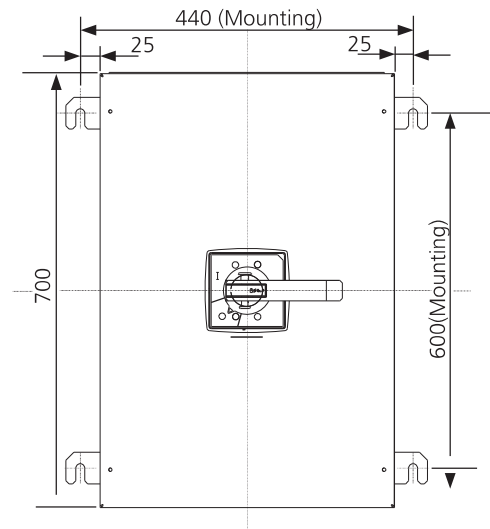
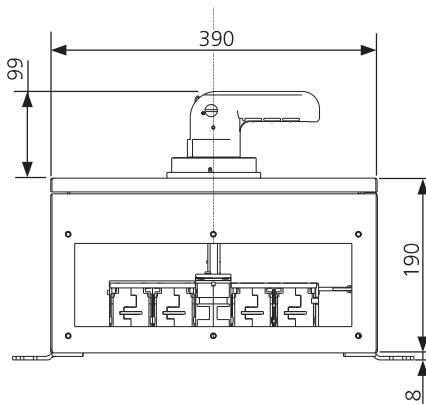

Termination Capacity

| | | | 315/400A | 630A |
|-------------------|--------------------------------------|----------------|---------------------------|---------------------------|
| | TERMINATION CAPACITY AS PER STANDARD | Cable With Lug | 2 X 150mm ² | 2 X 300mm ² |
| | | Busbar* | 2 X 25mm X 10mm | 2 X 30mm X 12mm |
| | MAXIMUM TERMINATION CAPACITY | Cable With Lug | 2 X 300mm ² | 2 X 300mm ² |
| | | Busbar* | 2 X 50mm X 12mm | 2 X 50mm X 12mm |
| TIGHTENING TORQUE | | | MAX 27 N-m AT TERMINATION | MAX 27 N-m AT TERMINATION |

Note: For Aluminum cable, Tin plated lugs are recommended. Termination bolt head should be on bottom side as shown in figures

Contents

| | |
|--------------------------|----|
| Product Range | 48 |
| Product Features | 49 |
| Universal Mounting | 55 |
| Technical Specifications | 67 |
| Spares and Accessories | 69 |
| Ordering Information | 71 |
| Overall Dimensions | 72 |

Product Range

FN & C-line offers you a unique series of Switch-Disconnecter combining compactness with high performance & Customer convenience.

Range covers ratings from 32 A to 2000 A in 6 frame sizes.

Versions

2P FN S-D suitable for open execution

The 2P FN S-D range is available from 32 A to 1000 A, suitable for 220V DC application.



TPN FN S-D suitable for open execution

The TPN FN S-D range is available from 32 A to 1000 A, suitable for 415/690V AC & 440V DC application.



TP & FP C-line S-D suitable for open execution

The 3P & 4P C-line S-D range is available from 1000 A to 2000 A, suitable for 690V AC & 440V DC application.



| Type Frame No. | Frame No. | Ratings (A) | | | |
|----------------|-----------|-------------|------|------|------|
| I | I | 32 | 63 | - | - |
| | II | 100 | 125 | - | - |
| | FN m | 200 | 250 | - | - |
| | IV | 315 | 400 | - | - |
| | V | 630 | 800 | 1000 | - |
| C-Line | VI | 1000 | 1250 | 1600 | 2000 |

FN S-D Product Features

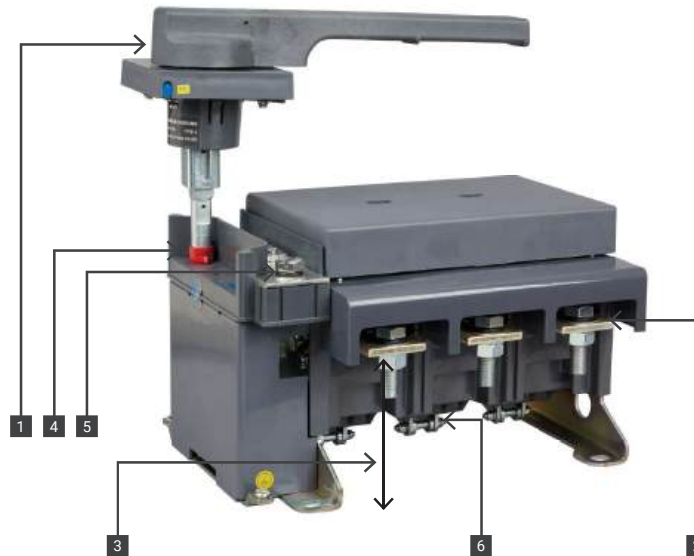

1. Handle

The FN Switch has a unique operating handle with the following features.

- › Door interlock for safety of operating personnel when switch is 'ON'. The interlock can be defeated if required
- › Built-in padlocking arrangement to lock the unit in 'OFF' position
- › The handle coupling can take a mismatch or $\pm 3\text{mm}$ in all directions
- › IP54 with extended operating handle



2. Maximum termination capacity

FN switch range provides generous terminal capacity in its compact size, facilitating aluminium termination.

3. Ground clearance

Higher ground clearance between terminals and mounting base plate ensures adequate clearance even after connecting cables. This eliminates the possibility of phase to ground flash over.

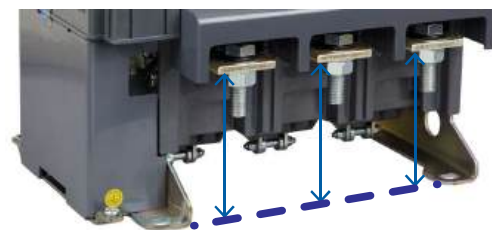

Product Range

4. Positive ON / OFF indication of S-D

The FN Switch indicates true position of contacts. (By a red pointer)



5. Built-in neutral

The FN TPN Switch consists of an integral neutral, making the units suitable for 3 phase, 4-wire application. FN 32 / 63 has switched neutral while higher ratings have isolable neutral. (For higher ratings switchable neutral kit is available as an accessory)

6. Contact system

Contact system is QUAD BREAK. There are number of parallel moving contacts per pole per break. Hence, better arc quenching & more electrical life of contacts. Each pole has separate bridge carrying the moving contacts, achieving a high order of inter phase separation & avoiding phase-phase flash over.

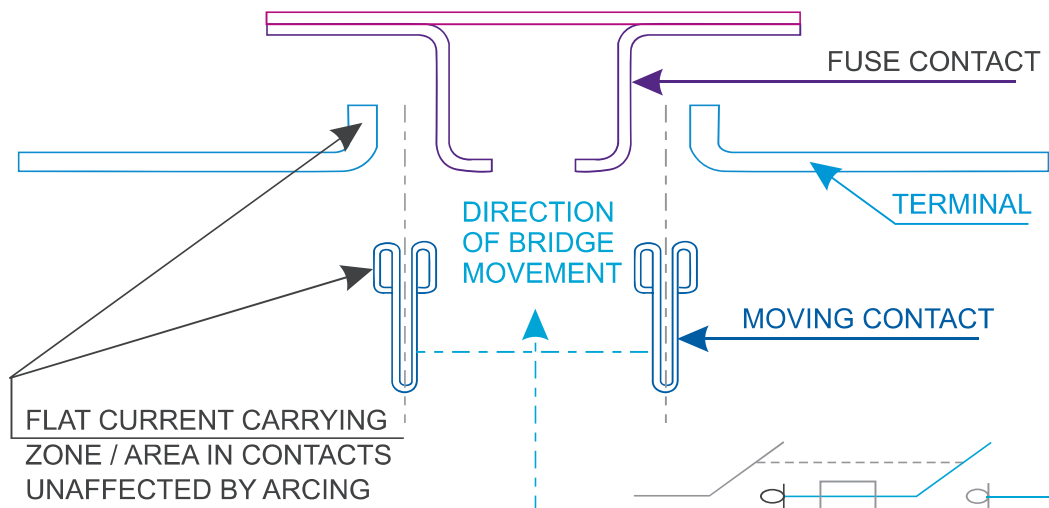

C-Line SD Product Features

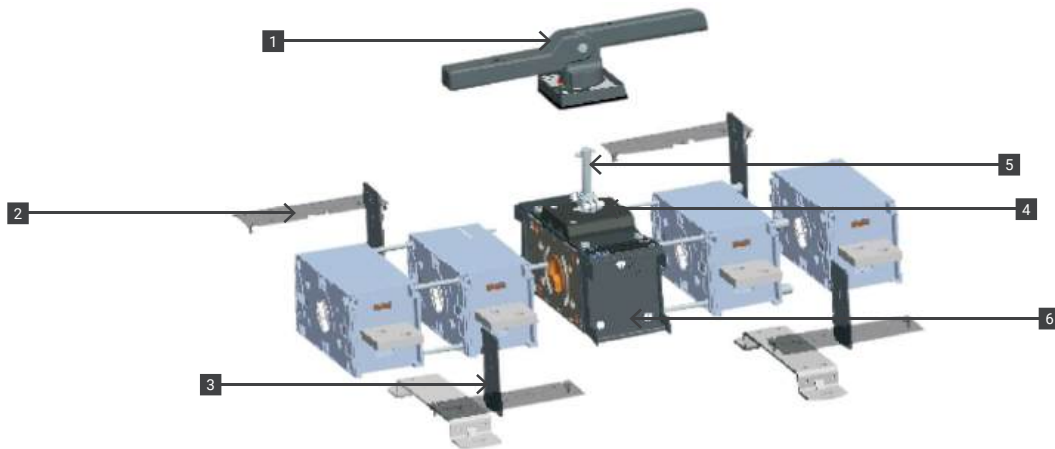

1. Handle

The C-line Switch has a unique flip-able operating handle which enables user to operate the switch with two hands. The handle also offers the following.

Features:

- › Door interlock for safety of operating personnel when switch is 'ON'. The interlock can be defeated if required
- › Built-in padlocking arrangement to lock the unit in 'OFF' position with 3 padlocks of 05 to 07
- › IP54 with extended type operating handle



2. Terminal shroud

These shrouds provide complete touch proof design and prevent accidental touching of live terminals. They are click fit type. Due to the hinge type terminal shrouds, it can be turned by 90 degree, hence terminals can be inspected without removing these shrouds.



Product Range

3. Inter-phase barriers

Inter-phase barriers are provided for additional safety to eliminate possibility of inter-phase short-circuit.



4. Positive ON / OFF indication of S-D

The C-line Switch indicates true position of contacts.

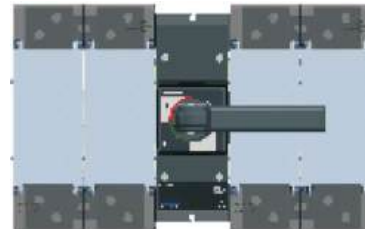

5. Depth adjustable operating shaft

The C-line Switch depth can be varied and fixed as per requirement during the installation which is possible due to stepless adjustment of operating shaft.

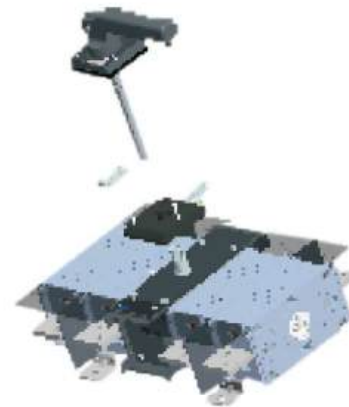

6. Mechanism and Contact System

Contact system is of double break, knife type having self wiping action with electrodynamic compensation. This ensures reliable performance during normal as well as short circuit fault conditions, offering higher short-time withstand rating.

C-line switch offers high electrical and mechanical life in compact size. The electrical and mechanical life are two times the requirement of the standard.

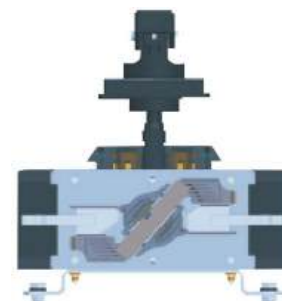

Universal Mounting

FN & C-line switch range offers a distinctive feature to mount S-D in different quadrants. This feature aids mounting flexibility.

FN S-D operating quadrant chart

(Seen from front of the door)

In FN Switch universal mounting is achieved by Type A and Type B handle.

Type A : Supplied as standard with all Switches

Type B : Available as an accessory

| Sr. No. | Handle (OFF) Position | Operating Quadrant (hand) | Switch Orientation | Door Cut-out | Handle Coupling Type |
|---------|-----------------------|---------------------------|--------------------|--------------|----------------------|
| 1 | | | | | B |
| 2 | | | | | A |
| 3 | | | | | A |
| 4 | | | | | B |
| 5 | | | | | B |
| 6 | | | | | A |
| 7 | | | | | A |
| 8 | | | | | B |

Note : Arrow (↔) indicates position of Interlock defeat key

Product Range

C-line S-D Operating Quadrant chart

(Seen from front of the door)

| Sr. No. | Handle (OFF) Position | Operating Quadrant (hand) | Switch Orientation | Door Cut-out | Shaft Position |
|---------|-----------------------|---------------------------|--------------------|--------------|----------------|
| 1 | | | | | |
| 2 | | | | | |
| 3 | | | | | |
| 4 | | | | | |

Technical Specifications

| Frame Size | | I | | II | | III | |
|------------------------------------------------------------------------------|--------------------|-----------------------------------------------|------------|------------|------------|------------|------------|
| Type Designation | Unit | FN 32 | FN 63 | FN 100 | FN 125 | FN 200 | FN250 |
| Reference standards | - | IEC 60947 - 3, EN 60947 - 3, IS/IEC 60947 - 3 | | | | | |
| No. of poles | - | 3P+Neutral | 3P+Neutral | 3P+Neutral | 3P+Neutral | 3P+Neutral | 3P+Neutral |
| Neutral | - | Switchable | Switchable | Isolable | Isolable | Isolable | Isolable |
| Rated operational voltage (Ue) | (V AC) | 415 | 415 | 415 | 415 | 415 | 415 |
| Rated insulation voltage (Ui) | (V AC) | 690 | 690 | 690 | 690 | 690 | 690 |
| Rated impulse withstand voltage (imp) | (kV AC) | 8 | 8 | 8 | 8 | 8 | 8 |
| Rated frequency | (HZ) | 50/60 | 50/60 | 50/60 | 50/60 | 50/60 | 50/60 |
| Service temperature | (°C) | -20 to 50 | -20 to 50 | -20 to 50 | -20 to 50 | -20 to 50 | -20 to 50 |
| Pollution degree | - | 3 | 3 | 3 | 3 | 3 | 3 |
| Conventional enclosed thermal current, I _{the} at 40 Deg C | (A) | 32 | 63 | 100 | 125 | 200 | 250 |
| Conventional free air thermal current, I _{th} at 40 Deg C | (A) | 32 | 63 | 100 | 125 | 200 | 250 |
| Rated operational current, I _e for AC 21 A / AC 22A | (A) | 32 | 63 | 100 | 125 | 200 | 250 |
| Rated operational current, I _e for AC 23A | (A) | 32 | 63 | 100 | 125 | 200 | 250 |
| Rated breaking capacity (436 V, cosφ=0.35) | (A) | 256 | 504 | 800 | 1000 | 1600 | 2000 |
| Rated making capacity (436 V, cosφ=0.35) | (A) | 320 | 630 | 1000 | 1250 | 2000 | 2500 |
| Short time withstand, I _{low} for 1 sec | (kA) | 1.5 | 1.5 | 4 | 4 | 6 | 8 |
| Rated operational power for AC 23A, cosφ=0.35 | (kW) | 15 | 29 | 47 | 58 | 93 | 117 |
| Capacitor duty -415 V 50 - 60 Hz | (kVAR) | 12 | 23 | 36 | 45 | 72 | 90 |
| Mechanical endurance | (operating cycles) | 15000 | 15000 | 15000 | 15000 | 10000 | 10000 |
| Operating torque | (N-m) | 4 | 4 | 4 | 12 | 20 | 20 |
| Terminal Capacity | | | | | | | |
| Terminal capacity (main) | (Sq mm) | 35 | 35 | 95 | 95 | 240 | 240 |
| Terminal capacity (neutral) | (Sq mm) | 35 | 35 | 50 | 50 | 120 | 120 |
| DC Rating for DC 22B | | | | | | | |
| Rated operational current, I _e at 220 V DC (2P in series) | (A) | 32 | 63 | 100 | 125 | 200 | 250 |
| Rated operational current, I _e at 440 V DC (3P in series) | (A) | 32 | 63 | 100 | 125 | 200 | 250 |
| Rated operational current, I _e at 750 V DC (2P in series, DC-20B) | (A) | - | - | - | - | - | - |
| AC Rating for 690 V AC Operational Voltage | | | | | | | |
| Rated operational current, I _e for AC 21A/ AC 228 | (A) | 32 | 63 | 63 | 100 | 160 | 200 |

| IV | | V | | | VI | | | |
|------------------------------------------------------|------------|------------|------------|------------|-------------|-------------|-------------|-------------|
| FN 315 | FN400 | FN 630 | FN 800 | FN 1000 | COS SD 1000 | COS SD 1250 | COS SD 1600 | COS SD 2000 |
| IEC 60947 - 3, EN 60947 - 3, IS/IEC 60947 - 3 | | | | | | | | |
| 3P+Neutral | 3P+Neutral | 3P+Neutral | 3P+Neutral | 3P+Neutral | 3P/4P | 3P/4P | 3P/4P | 3P/4P |
| Isolable | Isolable | Isolable | Isolable | Isolable | - | - | - | - |
| 415 | 415 | 415 | 415 | 415 | 415 | 415 | 415 | 415 |
| 690 | 690 | 690 | 690 | 690 | 1000 | 1000 | 1000 | 1000 |
| 8 | 8 | 8 | 8 | 8 | 12 | 12 | 12 | 12 |
| 50/60 | 50/60 | 50/60 | 50/60 | 50/60 | 50/60 | 50/60 | 50/60 | 50/60 |
| -20 to 50 | -20 to 50 | -20 to 50 | -20 to 50 | -20 to 50 | -20 to 50 | -20 to 50 | -20 to 50 | -20 to 50 |
| 3 | 3 | 3 | 3 | 3 | 3 | 3 | 3 | 3 |
| 315 | 400 | 630 | 800 | 1000 | 1000 | 1250 | 1600 | 2000 |
| 315 | 400 | 630 | 800 | 1000 | 1000 | 1250 | 1600 | 2000 |
| 315 | 400 | 630 | 800 | 1000 | 1000 | 1250 | 1600 | 2000 |
| 315 | 400 | 630 | 800 | 1000 | 1000 | 1250 | 1250 | 1250 |
| 2520 | 3200 | 5040 | 6400 | 8000 | 8000 | 10000 | 10000 | 10000 |
| 3150 | 4000 | 6300 | 8000 | 10000 | 10000 | 12500 | 12500 | 12500 |
| 14 | 14 | 20 | 20 | 25 | 50 | 50 | 50 | 50 |
| 147 | 187 | 294 | 374 | 374 | 467 | 584 | 748 | 934 |
| 113 | 144 | 226 | 288 | 288 | 546 | 682 | 874 | 1092 |
| 10000 | 10000 | 10000 | 10000 | 5000 | 6000 | 6000 | 6000 | 6000 |
| 25 | 25 | 25 | 25 | 30 | 55 | 55 | 55 | 60 |
| IEC 60947 - 3, EN 60947 - 3, IS/IEC 60947 - 3 | | | | | | | | |
| 400 | 2 x 400 | 2 x 625 | 2 x 625 | 2 x 625 | 2 x 5 x 80 | 2 x 5 x 80 | 2 x 5 x 100 | 3 x 5 x 100 |
| 240 | 240 | 400 | 400 | 400 | 2 x 5 x 80 | 2 x 5 x 80 | 2 x 5 x 100 | 3 x 5 x 100 |
| IEC 60947 - 3, EN 60947 - 3, IS/IEC 60947 - 3 | | | | | | | | |
| 315 | 400 | 630 | 800 | 1000 | 1000 | 1250 | 1600 | 2000 |
| 315 | 400 | 630 | 800 | 1000 | 1000 | 1250 | 1600 | 2000 |
| - | - | - | - | - | 1000 | 1250 | 1600 | 2000 |
| IEC 60947 - 3, EN 60947 - 3, IS/IEC 60947 - 3 | | | | | | | | |
| 250 | 315 | 400 | 800 | 1000 | 1000 | 1250 | 1250 | 1250 |

Spares and Accessories

Wide range of spares & accessories are available for Switch-Disconnecter units

Type FN Spares & Accessories

Switched neutral

In FN 32 / 63 Switched-Neutral pole is an integral part of the Switch-Disconnecter-Fuse. For higher ratings, a double break, site-fitted switched neutral pole can be provided. This is operated by the main mechanism.



Terminal shroud

The terminals can be shrouded for protection against phase-short circuit through an external conducting path and against accidental human contact with live terminals.



Castell interlock

Switch-Disconnecter-Fuse units can be locked on OFF position with help of castell interlock. Castell interlock can also be used to interlock two SDF units. (Different variety of locks are available).



Handle coupling (type A & B)

Irrespective of the switch orientation (vertical or horizontal), operation in any of the four quadrants is possible by selecting right handle coupling (Refer universal mounting table).



Auxiliary contacts

1 NO + 1 NC auxiliary contact is available as an accessory. This can be suitably wired in the control circuit.

- › Rated operational current I. (AC -1 5) -4 A
- › Rated operational voltage u. -415 V



Type C-line Spares & Accessories

Handle

The C-line S-D has a unique flip-able operating handle which enables user to operate the switch with two hands. Irrespective of the orientation, operation in any of the four quadrants is possible. (refer universal mounting table)



Auxiliary contact kit

It consists of one set of changeover contacts. This kit is pre-wired with terminal blocks and can be fitted at the site without increasing overall dimension

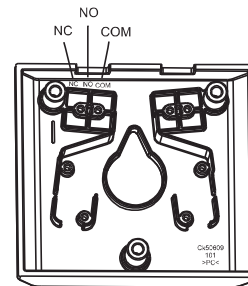

Castell lock

Accessory to lock the switch in OFF state and using this can have interlocking schemes between multiple switches.



Ordering Information

FN S-D suitable for open execution:

| Operating Current Rating (A) | 32 | 63 | 100 | 125 |
|------------------------------|-------------|-------------|-------------|-------------|
| 2P S-D Version | SK904180000 | SK904190000 | SK904200000 | SK904210000 |
| TPN S-D Version | SK955410000 | SK955400000 | SK955710000 | SK954050000 |

| Operating Current Rating (A) | 200 | 250 | 315 | 400 |
|------------------------------|-------------|-------------|-------------|-------------|
| 2P S-D Version | SK904500000 | SK904540000 | SK904650000 | SK904660000 |
| TPN S-D Version | SK956070000 | SK956830000 | SK956090000 | SK956100000 |

| Operating Current Rating (A) | 630 | 800 | 1000 |
|------------------------------|-------------|-------------|-------------|
| 2P S-D Version | SK904670000 | SK904680000 | SK904690000 |
| TPN S-D Version | SK956110000 | SK955510000 | SK957100000 |

C-line S-D suitable for open execution

| Operating Current Rating (A) | 1000 | 1250 | 1600 | 400 |
|------------------------------|-------------|-------------|-------------|-------------|
| TP S-D Version | COS10000030 | COS12500030 | COS16000030 | COS20000030 |
| FP S-D Version | COS10000040 | COS12500040 | COS16000040 | COS20000040 |

Overall Dimensions

Switch-Disconnecter Type FN32 / FN63 2P

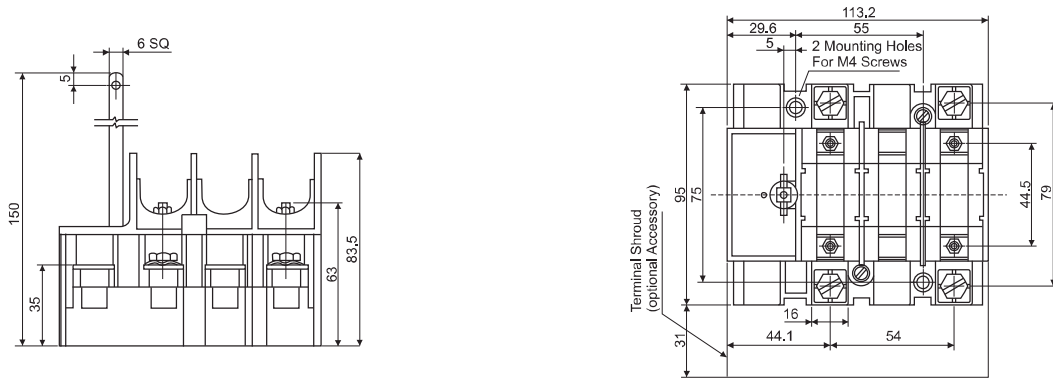

Switch-Disconnecter Type FN100 / FN125 2P

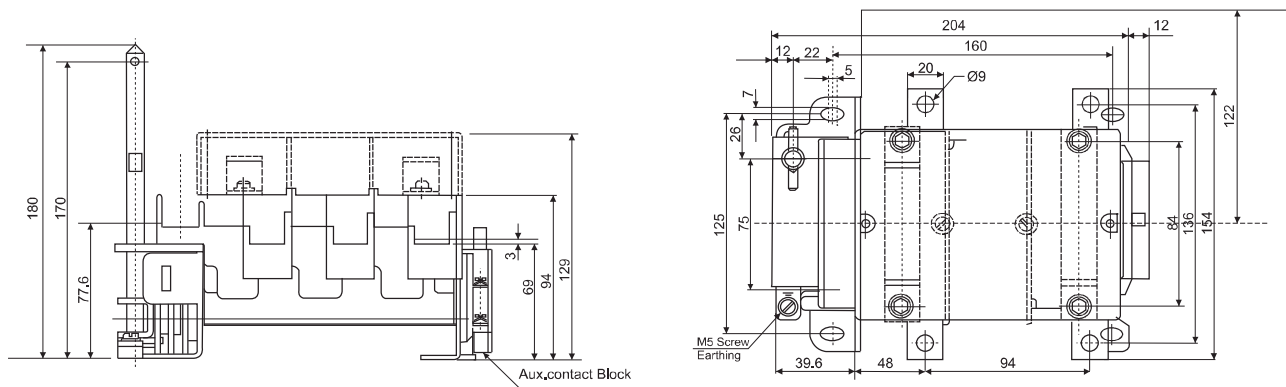

Note : All dimensions are in mm.

Overall Dimensions

Switch-Disconnecter Type FN200 / FN250 2P

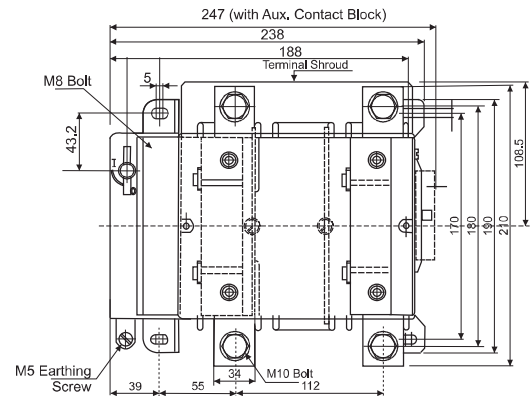
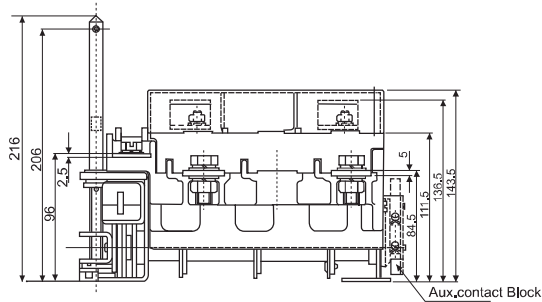

Switch-Disconnecter Type FN315 / FN400 2P

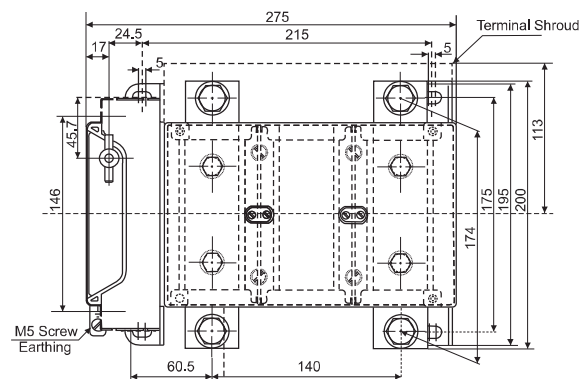
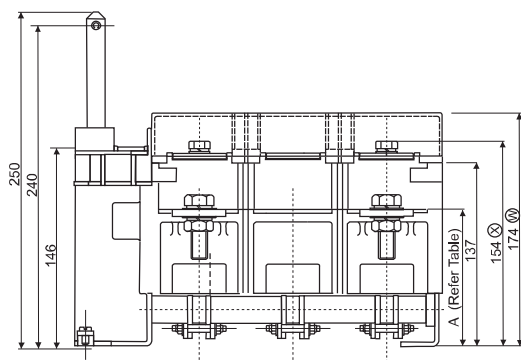

Note : All dimensions are in mm.

Overall Dimensions

Switch-Disconnecter Type FN630 / FN800 2P

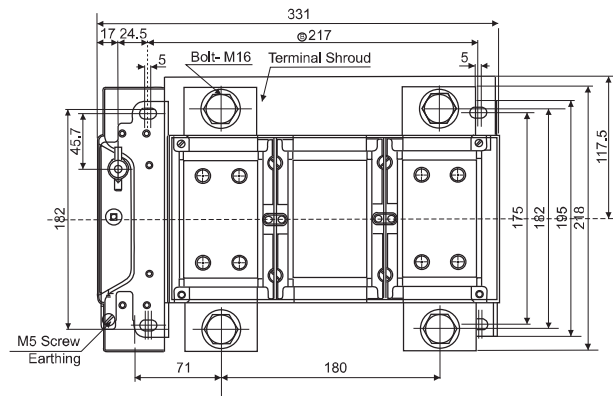
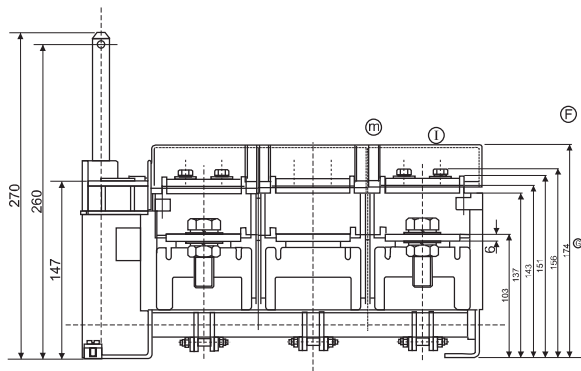

Switch-Disconnecter Type FN1000 2P

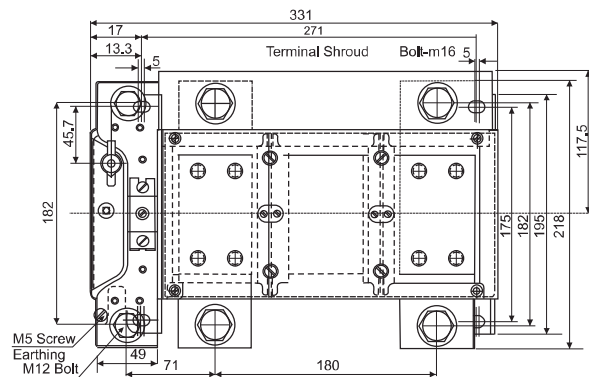
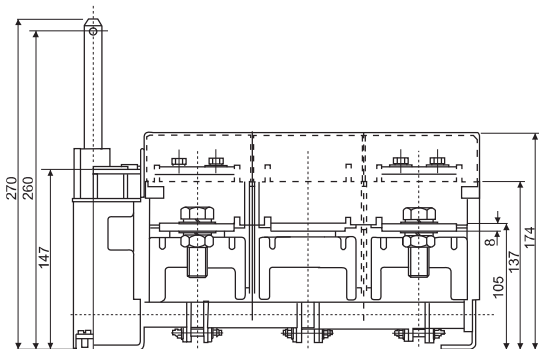

Note : All dimensions are in mm.

Overall Dimensions

Switch-Disconnecter Type FN32 / FN63 TPN

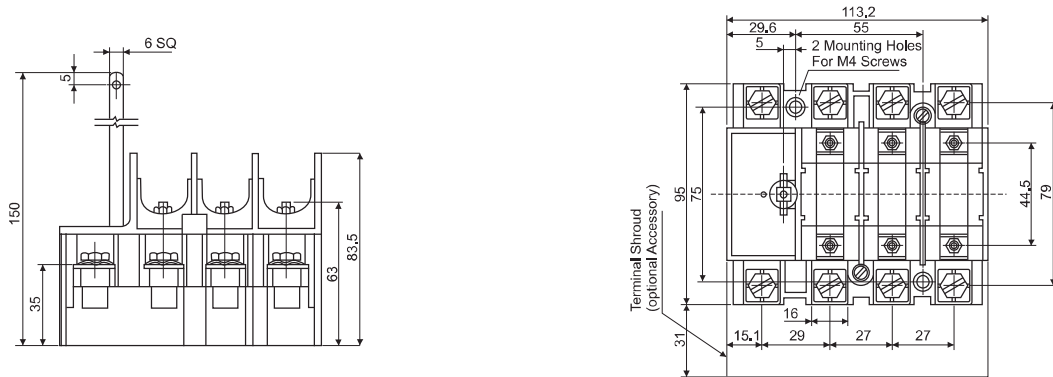

Switch-Disconnecter Type FN100 / FN125 TPN

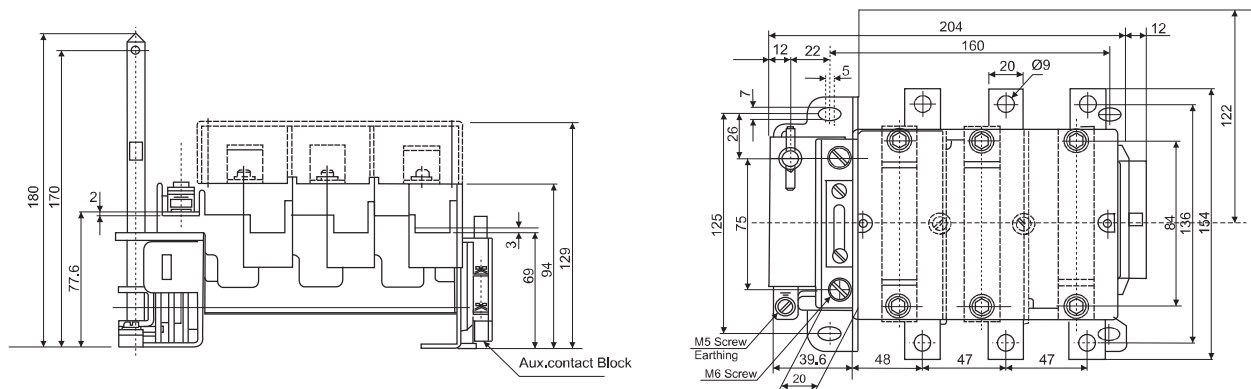

Note : All dimensions are in mm.

Overall Dimensions

Switch-Disconnecter Type FN200 / FN250 TPN

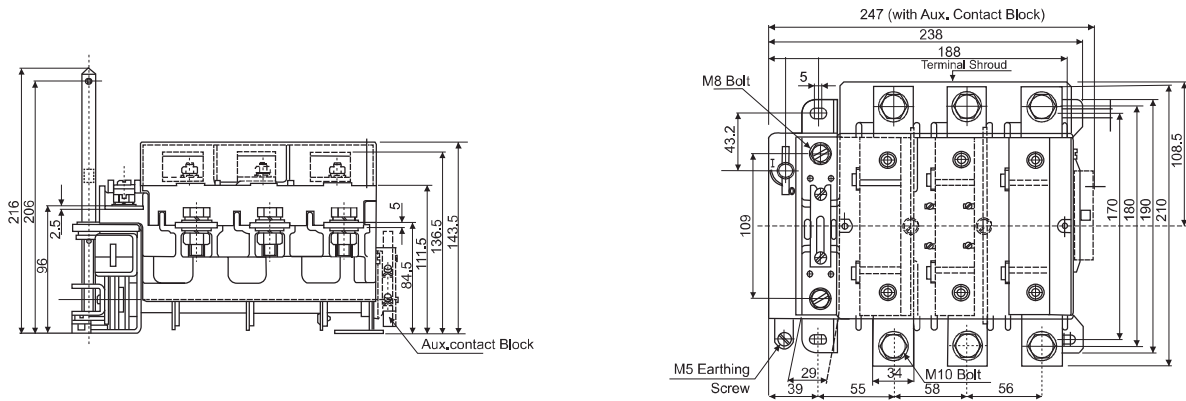

Switch-Disconnecter Type FN315 / FN400 TPN

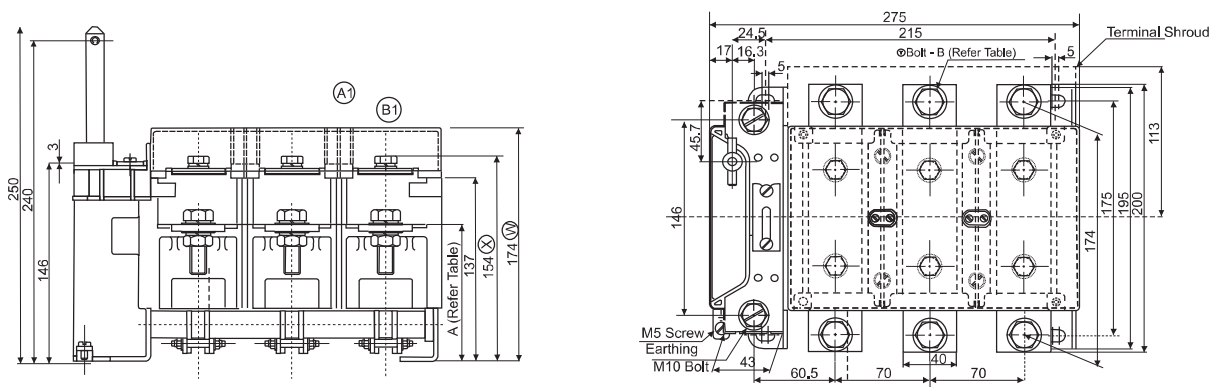

Note : All dimensions are in mm.

Overall Dimensions

Switch-Disconnecter Type FN630 / FN800 TPN

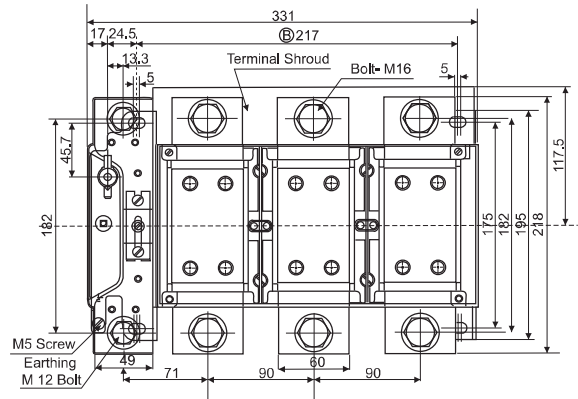
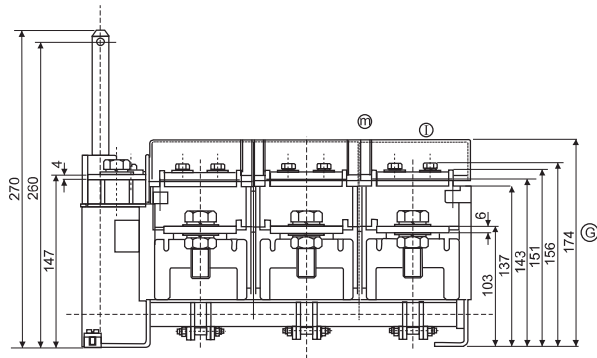

Switch-Disconnecter Type FN1000 TPN

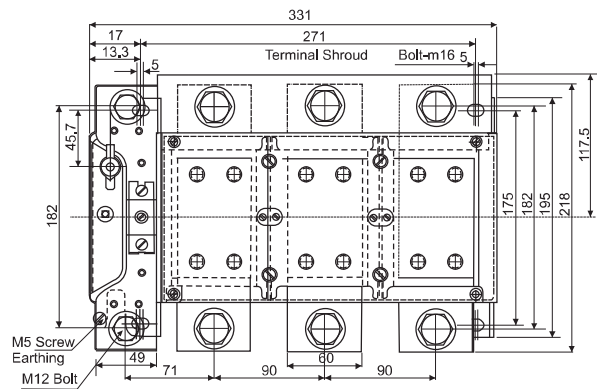
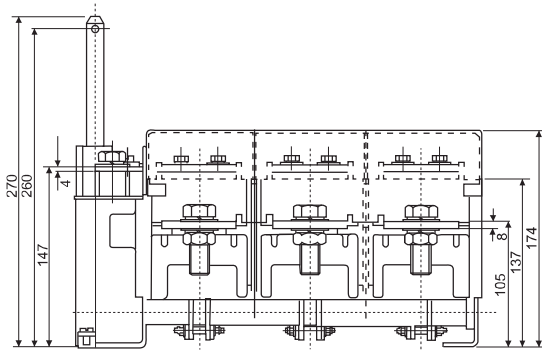

Note : All dimensions are in mm.

Overall Dimensions

Switch-Disconnecter Type COS1000/COS1250/COS1600A 3P

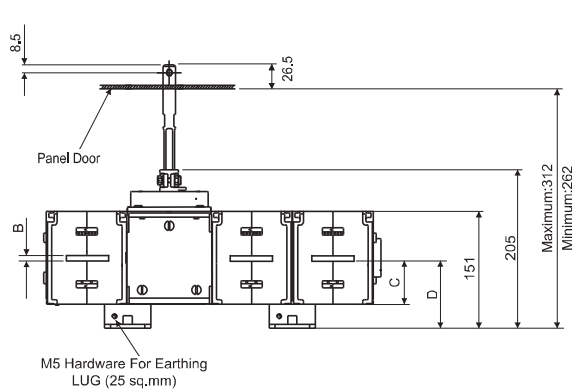

| Cat No. | Rating | A | B | C | D |
|-------------|--------|-----|----|----|----|
| COS1000O03O | 1000 | 310 | 8 | 56 | 87 |
| COS1250O03O | 1250 | 310 | 8 | 56 | 87 |
| COS1600O03O | 1600 | 330 | 12 | 54 | 85 |

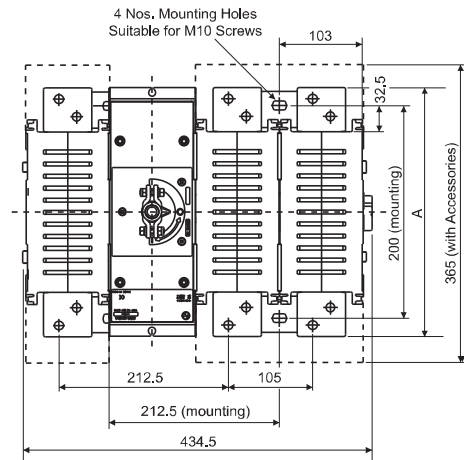

Switch-Disconnecter Type COS2000 3P

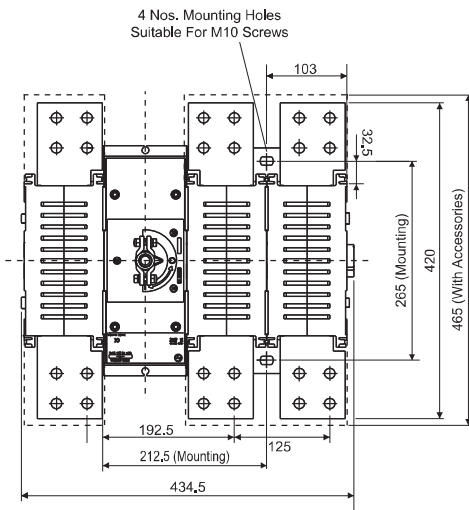
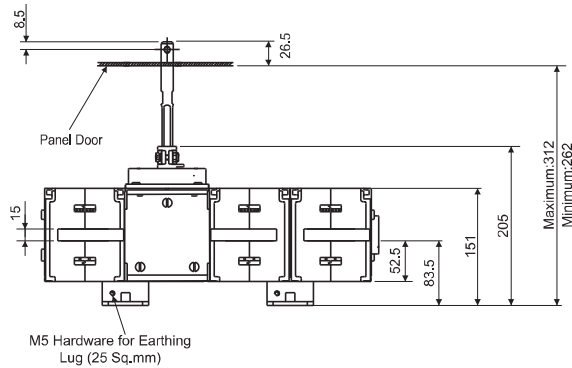

Note : All dimensions are in mm.

Overall Dimensions

Switch-Disconnecter Type COS1000/COS1250/COS1600A 4P

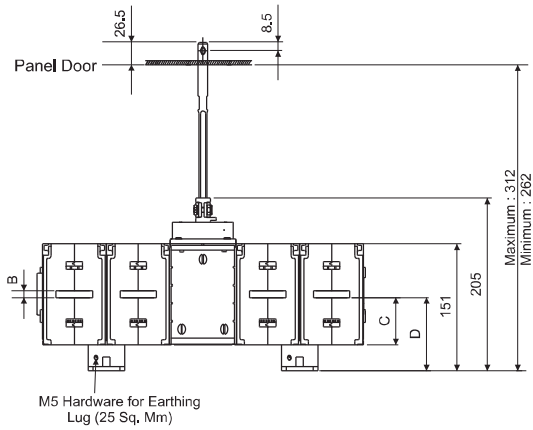

M5 Hardware for Earthing Lug (25 Sq. Mm)

| Type Designation | Terminal Screws | Tightening Torque |
|------------------|-------------------------|-------------------|
| COS-1000 | M10 Hexagonal Head Bolt | 20 N-m |
| COS-1250 | M10 Hexagonal Head Bolt | 20 N-m |
| COS-1600 | M12 Hexagonal Head Bolt | 27 N-m |

| Cat. No. | Rating | A | B | C | D |
|-------------|--------|-----|----|----|----|
| COS1000O04O | 1000 | 310 | 8 | 56 | 87 |
| COS1250O04O | 1250 | 310 | 8 | 56 | 87 |
| COS1600O04O | 1600 | 330 | 12 | 54 | 85 |

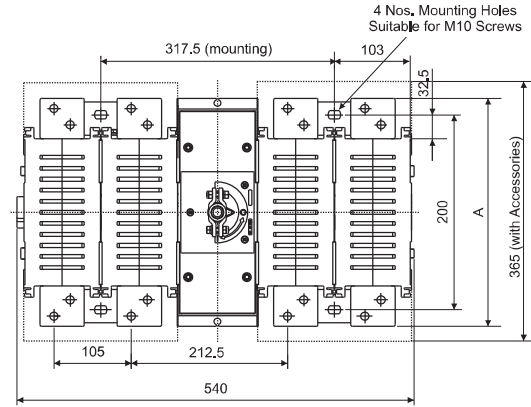

1000/1250 Terminal Arrangement

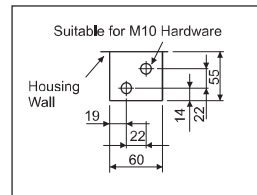

1600 Terminal Arrangement

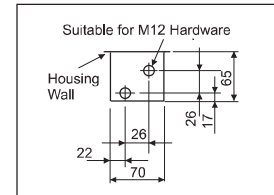

Switch-Disconnecter Type COS2000 4P

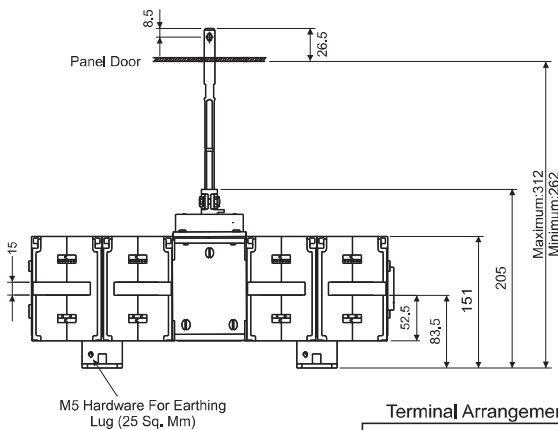

M5 Hardware For Earthing Lug (25 Sq. Mm)

Terminal Arrangement

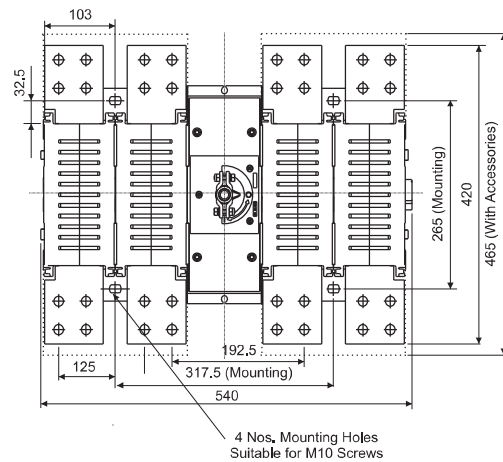
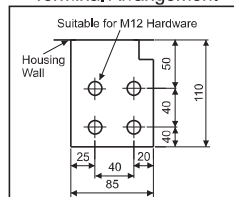

4 Nos. Mounting Holes Suitable for M10 Screws

Note : All dimensions are in mm.

Overall Dimensions

Termination Arrangement

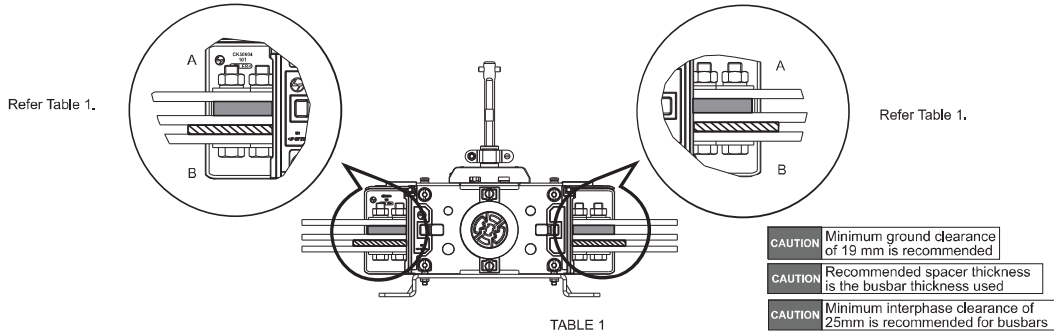
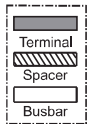

TABLE 1

| | | 1000/1250 A | 1600 A | 2000 A |
|----------------------------|---|-------------|--------|--------|
| Max Space for Bus Bar (mm) | A | 25 | 22 | 20 |
| Max Space for Bus Bar (mm) | B | 31 | 30 | 48 |



Busbar Sizes as Per Standard (Table 2) :

| Busbar | 1000 A | 1250 A | 1600 A | 2000 A |
|--------|----------------|----------------|----------------|-----------------|
| Cu | 60 x 5 x 2Nos | 80 x 5 x 2Nos | 100 x 5 x 2Nos | 100 x 5 x 3Nos |
| * Al | 50 x 10 x 2Nos | 63 x 12 x 2Nos | 50 x 8 x 4Nos | 100 x 10 x 3Nos |

*For Aluminium termination as per standard.
1250A: Factory fitted hardware used.
1600/2000A: Bolt length of 85mm used.

Note : 1. Different configurations of busbars can be used maintaining minimum cross section areas as specified in the table 2.
2. Factory supplied bolt length caters to the copper bus bar termination as per standard in case of different configurations & cross sectional areas. Bolt of higher length may be required.

Recommended Termination Practices for Busbar Width 60-80mm With Diagonal Hole Configuration

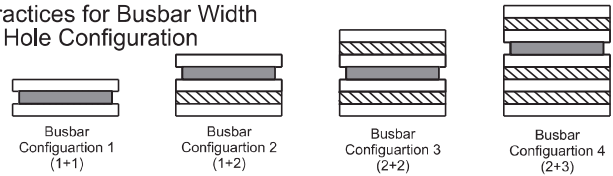

Termination of 100 mm Bus Bar

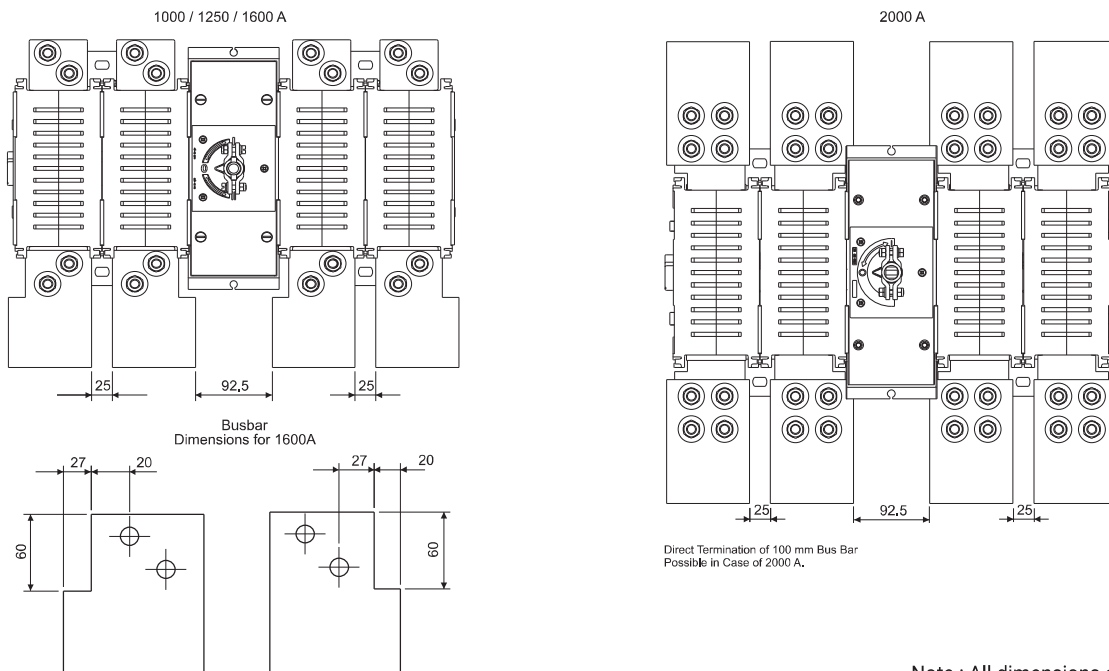

Note : All dimensions are in mm.

Overall Dimensions

Phase Barrier and Terminal Shroud Mounting

The accessories have to be fitted sequentially in the given order:
 1. Phase barriers 2. Terminal shrouds *

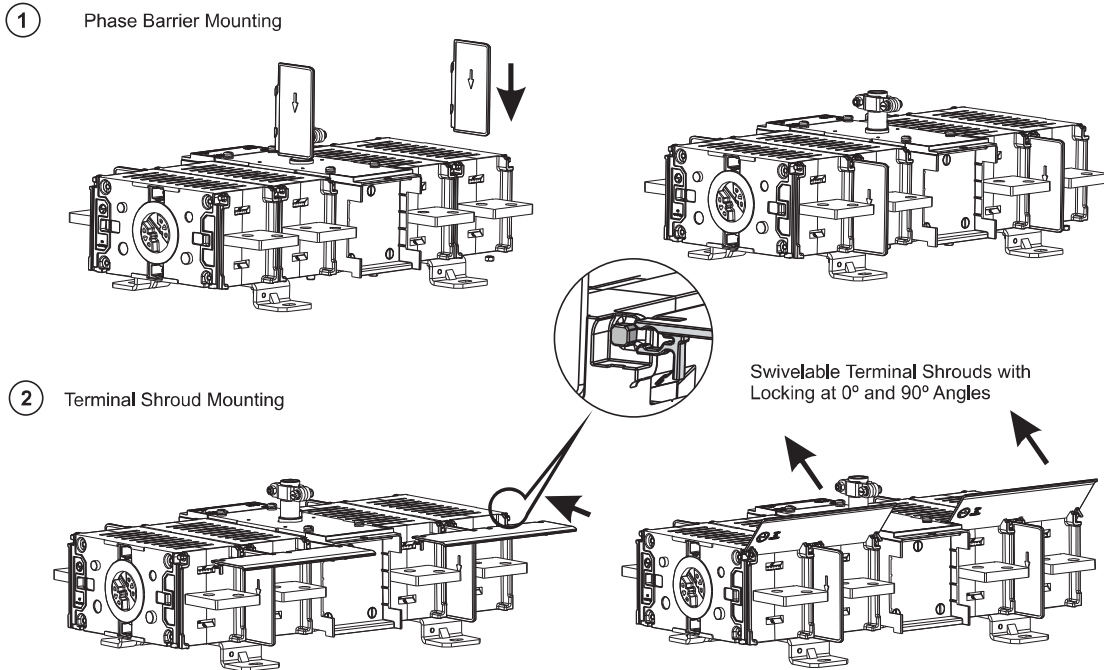

Shaft Adjustability

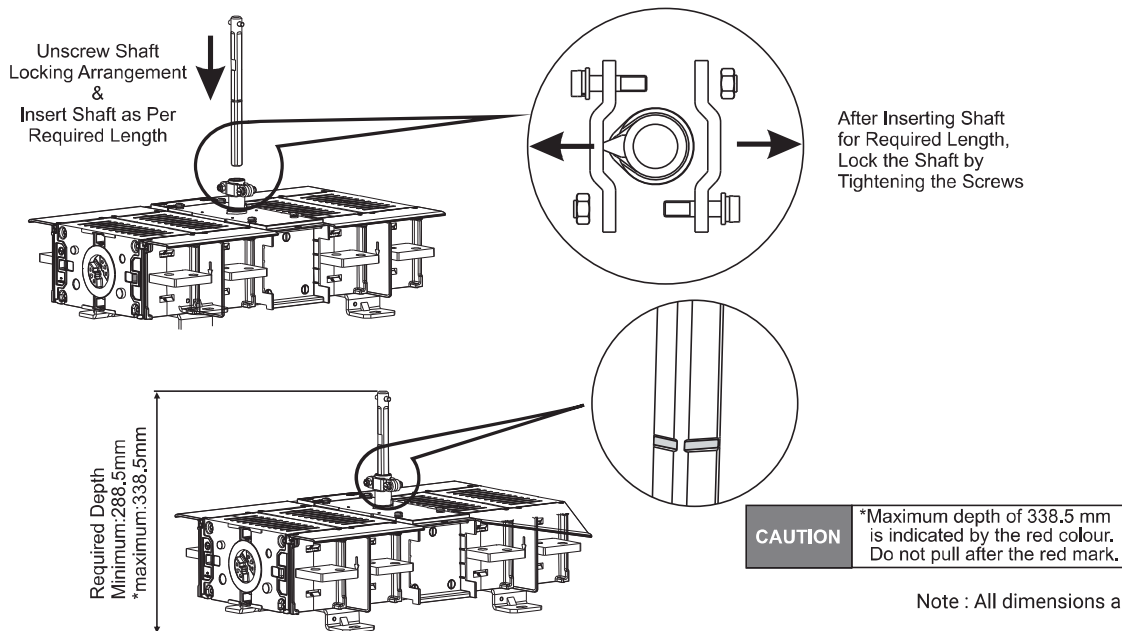

Note : All dimensions are in mm.

Overall Dimensions

Auxiliary Contact Mounting

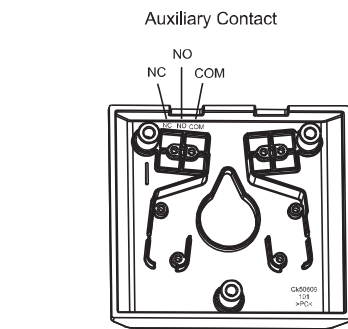

② Assemble the Aux. Contacts as Shown.

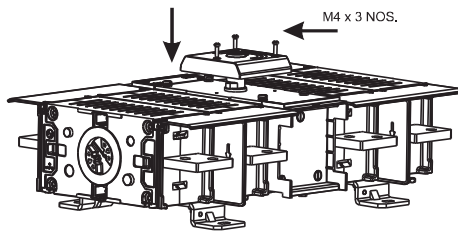

① Unscrew the Shaft Locking Arrangement and Remove Shaft

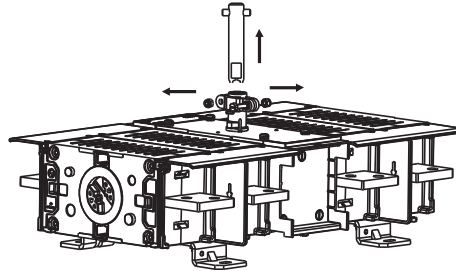

③ Insert Shaft to Required Length & Lock Shaft

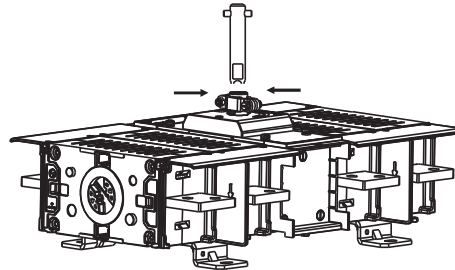

Mounting Orientation

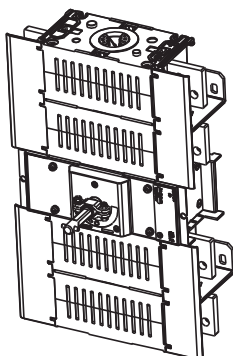
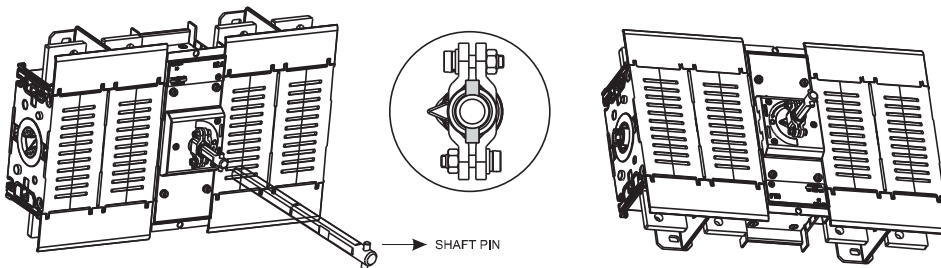

CAUTION

Ensure that the shaft pin is vertical for any mounting orientation of the switch

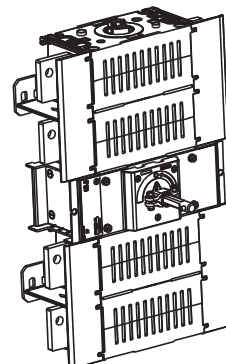

Note : All dimensions are in mm.

Overall Dimensions

Handle Overall Dimensions for Cos -1000 / 1250 / 1600 / 2000

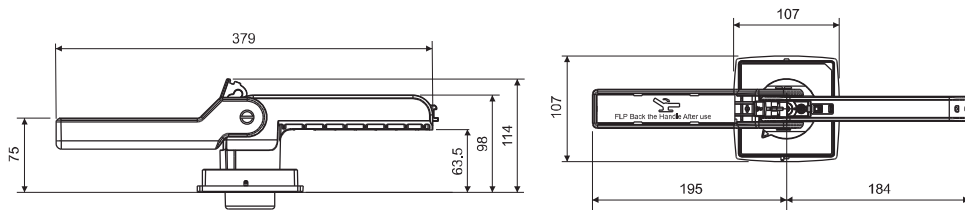

Handle Mounting

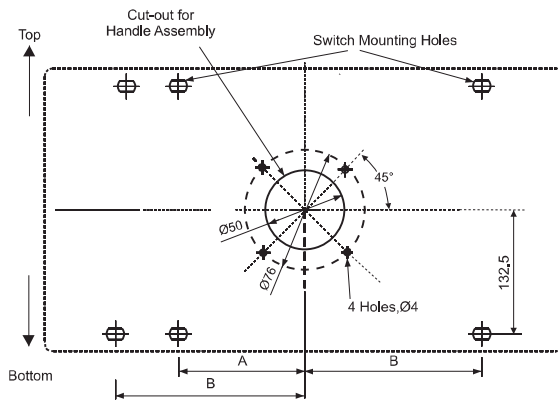

Mounting Dimensions

| | | |
|--------|---------------------|--|
| 3-POLE | A: 53,6 B: 158,9 | |
| 4-POLE | B: 158,9 | |

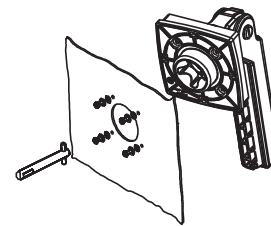

Handle Features

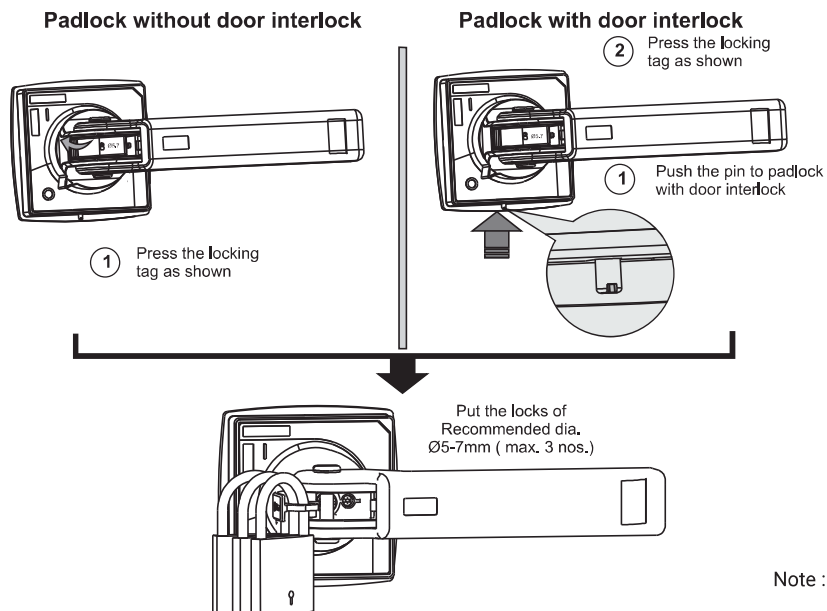

Note : All dimensions are in mm.

Overall Dimensions

Handle Features

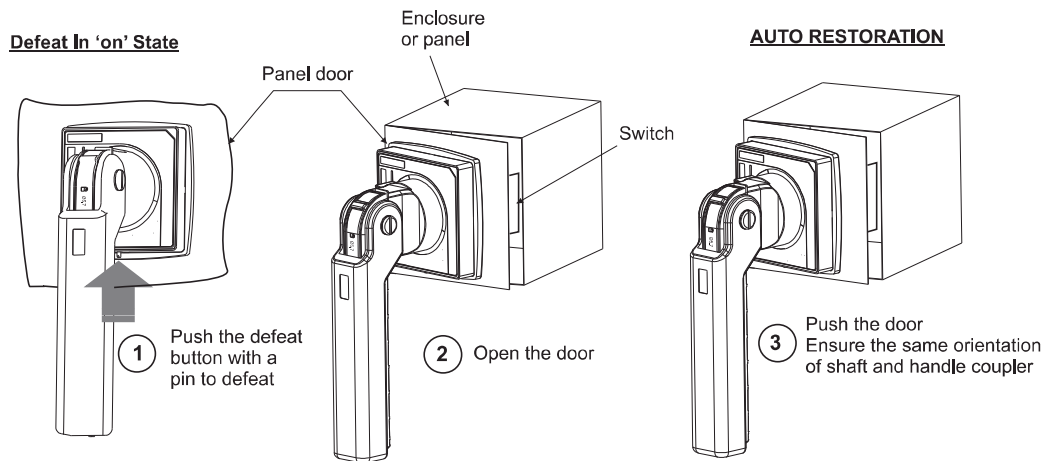

Handle Flipping

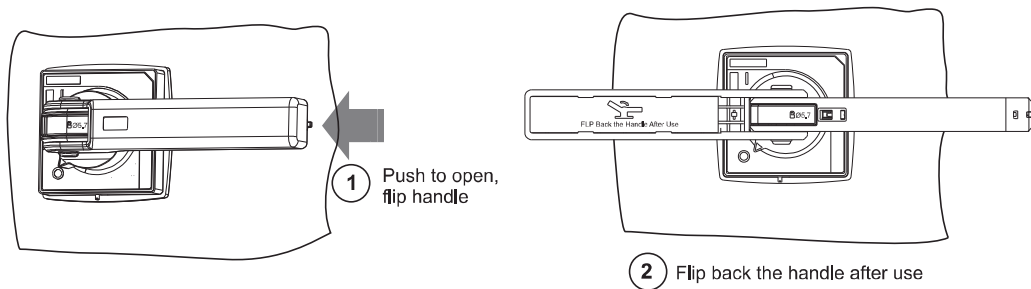

Note : All dimensions are in mm.

Electrical Standard Products (ESP) Offices

HEAD OFFICE

Lauritz Knudsen Electrical & Automation, A/600, Shil-Mahape Road, TTC Industrial Area, MIDC Thane, Navi Mumbai, 400 710, Maharashtra.

Tel: 022-6722 6300 | Fax: 022-6705 1112 | e-mail: CIC@LK-EA.com

BRANCH OFFICES

Lauritz Knudsen Electrical & Automation
C-201, The First Commercial Complex,
B/S Keshavbaug Party Plot, Vastrapur,
Ahmedabad - 380 015
Phone No: 022-6932 7800
e-mail: CIC@LK-EA.com

Lauritz Knudsen Electrical & Automation
Shri Daneshwari, 1st Floor,
Plot No. 17, 2nd Cross, Near Old Income
Tax Office Road, Vidyanagar,
Hubballi - 580 021
Phone No: 022-6932 7800
e-mail: CIC@LK-EA.com

Lauritz Knudsen Electrical & Automation
No.10, Fortuna Towers, 2nd Floor,
Rana Pratap Marg, Near NBRI,
Lucknow - 226 001
Phone No: 022-6932 7800
e-mail: CIC@LK-EA.com

Lauritz Knudsen Electrical & Automation
A06/A07, Second Floor,
Grand Chandra Complex, Frazer Road
Patna - 800 001
Phone No: 022-6932 7800
e-mail: CIC@LK-EA.com

Lauritz Knudsen Electrical & Automation
Wework Central, #36 Infantry Road,
Bengaluru - 560 001
Phone No: 022-6932 7800
e-mail: CIC@LK-EA.com

Lauritz Knudsen Electrical & Automation
AWFIS Space Solutions, Prestige Phoenix,
4th floor, 1405, Umanagar, Begumpet,
Hyderabad - 500 016
Phone No: 022-6932 7800
e-mail: CIC@LK-EA.com

Lauritz Knudsen Electrical & Automation
El Dorado Building, 3rd Floor, 6,
Venkatraman Street, Chinna Chokkikulam,
Madurai - 625 002
Phone No: 022-6932 7800
e-mail: CIC@LK-EA.com

Lauritz Knudsen Electrical & Automation
UrbanWrk, 5th Floor, Sai Radhe,
Raja Bahadur Mill Road, Behind Hotel
Grand Sheraton, Sangamwadi
Pune - 411 001
Phone No: 022-6932 7800
e-mail: CIC@LK-EA.com

Lauritz Knudsen Electrical & Automation
Under O Launchpad, 4th Floor,
Unit-434, Esplanade 1, Rasulgarh,
Bhubaneswar - 751 010
Phone No: 022-6932 7800
e-mail: CIC@LK-EA.com

Lauritz Knudsen Electrical & Automation
Workie, 214 - 2nd Floor,
Apollo Premier, PU-4,
Scheme No. 54, Vijay Nagar Square,
Indore - 452 010
Phone No: 022-6932 7800
e-mail: CIC@LK-EA.com

Lauritz Knudsen Electrical & Automation
Bestech Business Park,
Tower - A, 2nd floor, Sector - 66
Mohali - 160059
Phone No: 022-6932 7800
e-mail: CIC@LK-EA.com

Lauritz Knudsen Electrical & Automation
Office No. 211 & 212, Pithalia Plaza,
KK Road, Near Fafadih Chowk,
Raipur - 492 001
Phone No: 022-6932 7800
e-mail: CIC@LK-EA.com

Lauritz Knudsen Electrical & Automation,
801 Word Level-8, No. 28,
SIDCO Industrial Estate, Guindy,
Chennai - 600 032
Phone No: 022-6932 7800
e-mail: CIC@LK-EA.com

Lauritz Knudsen Electrical & Automation
Office No. 430, 4th Floor,
Jaipur Electronic Market, Riddhi Siddhi,
Gopalpura Bypass,
Jaipur - 302 018
Phone No: 022-6932 7800
e-mail: CIC@LK-EA.com

Lauritz Knudsen Electrical & Automation
TC II, Tower B, PRIMA BAY Gate No. 5,
Saki Vihar Road Powai,
Mumbai - 400 072
Phone No: 022-6932 7800
e-mail: CIC@LK-EA.com

Lauritz Knudsen Electrical & Automation,
DevX 4th Floor, A Wing, Om 9 Square,
150 Ft Ring Road, Near Nana Mava Circle,
Opp Silver Heights,
Rajkot - 360 001
Phone No: 022-6932 7800
e-mail: CIC@LK-EA.com

Lauritz Knudsen Electrical & Automation
Playworkz Coworking Space
43 & 44, 3rd Cross,
Bharathy Colony, Peelamedu,
Coimbatore - 641 004
Phone No: 022-6932 7800
e-mail: CIC@LK-EA.com

Lauritz Knudsen Electrical & Automation
GDR Siddha, Ground Floor, N Road
Bistupur, Opposite St. Mary's Church,
Jamshedpur - 831 001
Phone No: 022-6932 7800
e-mail: CIC@LK-EA.com

Lauritz Knudsen Electrical & Automation
Unnati Building, 2nd Floor,
Automation Campus, A-600, TTC Industrial
Area Shil-Mahape Road, Mahape,
Navi Mumbai - 400 710
Phone No: 022-6932 7800
e-mail: CIC@LK-EA.com

Lauritz Knudsen Electrical & Automation
10th Floor, Titaanium Business,
Bhimrad Road, Althan
Surat - 395 017
Phone No: 022-6932 7800
e-mail: CIC@LK-EA.com

Lauritz Knudsen Electrical & Automation
3rd Floor, 1&2 Vijay Park,
Main Chakrata Road, Opp. Anandam,
Near Ballupur chowk,
Dehradun - 248 001
Phone No: 022-6932 7800
e-mail: CIC@LK-EA.com

Lauritz Knudsen Electrical & Automation
Business Communication Centre
2nd Floor, Chiramel Chambers,
Kurisupally Road, Ravipuram,
Kochi - 682 015
Phone No: 022-6932 7800
e-mail: CIC@LK-EA.com

Lauritz Knudsen Electrical & Automation
M1 & M2, Mezzanine Floor,
Himalaya Excellency,
Plot No. C-47, Pratap Nagar Square,
Nagpur - 440 022
Phone No: 022-6932 7800
e-mail: CIC@LK-EA.com

Lauritz Knudsen Electrical & Automation
11th Floor, Block-D, Notus IT Park,
Sarabhai Campus, Bhailal Amin Marg,
Vadodra - 390 023
Phone No: 022-6932 7800
e-mail: CIC@LK-EA.com

Lauritz Knudsen Electrical & Automation
Ground Floor, B-27,
Biplab Rashbihari Sarani,
Sector 2A, Bidhan Nagar,
Durgapur - 713 212
Phone No: 022-6932 7800
e-mail: CIC@LK-EA.com

Lauritz Knudsen Electrical & Automation,
207, 2nd floor, Revolution Complex,
Station Road, E Ward,
Next to Pedestrian Bridge,
Kolhapur - 416 001
Phone No: 022-6932 7800
e-mail: CIC@LK-EA.com

Lauritz Knudsen Electrical & Automation,
3rd floor, Uttam Tower by Viraj Estate,
Sharanpur Road,
Nasik - 422 002
Phone No: 022-6932 7800
e-mail: CIC@LK-EA.com

Lauritz Knudsen Electrical & Automation
Naga Chambers, 3rd Floor, D/No. 12-1-16,
Plot No. 49, Survey No. 1051, Waltair Main Road,
Visakhapatnam - 530 002
Phone No: 022-6932 7800
e-mail: CIC@LK-EA.com

Lauritz Knudsen Electrical & Automation
6th Floor, Exotica Greens, A Block, 191,
R G Baruah Road, Guwahati Central,
Guwahati - 781 005
Phone No: 022-6932 7800
e-mail: CIC@LK-EA.com

Lauritz Knudsen Electrical & Automation
2nd Floor, BN3, Salt Lake, Sector-V,
Kolkata - 700 091
Phone No: 022-6932 7800
e-mail: CIC@LK-EA.com

Lauritz Knudsen Electrical & Automation
A-25, 1st Floor, Imperia Complex,
Moham Corporate Industrial Estate,
Near Sarita Vihar Metro Station,
Mathura Road,
New Delhi - 110 044
Phone no: 022-6932 7800
e-mail: CIC@LK-EA.com

Product improvement is a continuous process. For the latest information and special application, please contact any of our offices listed here. Product photographs shown for representative purpose only.



Electrical & Automation

Lauritz Knudsen Electrical & Automation, Electrical Standard Product
A/600, Shil-Mahape Road, TTC Industrial Area, MIDC Thane, Navi Mumbai, 400 710,
Maharashtra, Phone No: 022-6722 6300 | Web: www.LK-EA.com

Customer Interaction Center (CIC)
Phone no: 022-6932 7800
Web: www.LK-EA.com | e-mail: CIC@LK-EA.com